

DH 95 S

EN

ORIGINAL INSTRUCTIONS
CONDENSER DRYER

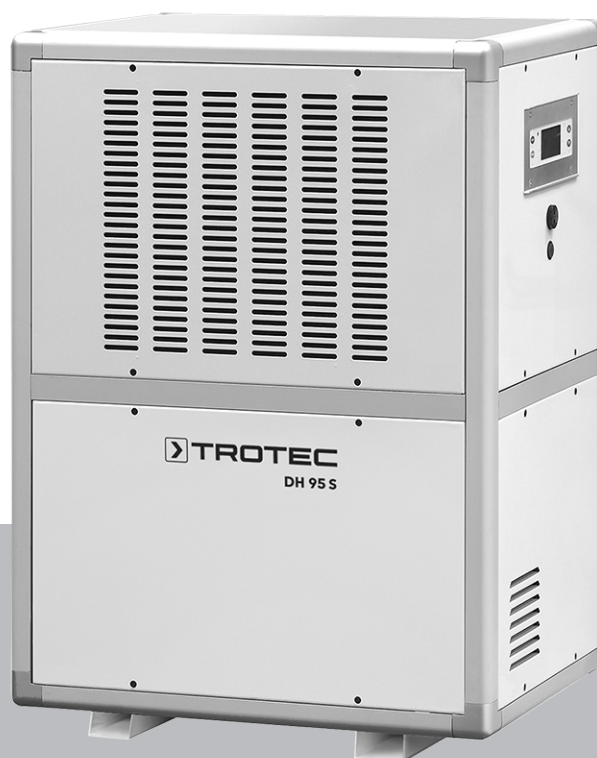

 TROTEC

Table of contents

Notes regarding the instructions 2

Safety 2

Information about the device 4

Transport and storage 5

Assembly and start-up 6

Operation 8

Errors and faults 10

Maintenance 11

Technical annex 13

Disposal 17

Declaration of conformity 17

Notes regarding the instructions

Symbols



Warning of electrical voltage

This symbol indicates dangers to the life and health of persons due to electrical voltage.



Warning

This signal word indicates a hazard with an average risk level which, if not avoided, can result in serious injury or death.



Caution

This signal word indicates a hazard with a low risk level which, if not avoided, can result in minor or moderate injury.

Note

This signal word indicates important information (e.g. material damage), but does not indicate hazards.



Info

Information marked with this symbol helps you to carry out your tasks quickly and safely.



Follow the manual

Information marked with this symbol indicates that the instructions must be observed.

You can download the current version of the instructions via the following link:

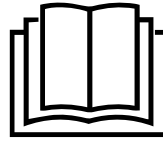

DH 95 S



<https://hub.trotec.com/?id=43486>

Safety

Read this manual carefully before starting or using the device. Always store the manual in the immediate vicinity of the device or its site of use.



Warning

Read all safety warnings and all instructions.

Failure to follow the warnings and instructions may result in electric shock, fire and/or serious injury.

Save all warnings and instructions for future reference.

This appliance can be used by children aged from 8 years and above and persons with reduced physical, sensory or mental capabilities or lack of experience and knowledge if they have been given supervision or instruction concerning use of the appliance in a safe way and understand the hazards involved.

Children shall not play with the appliance. Cleaning and user maintenance shall not be made by children without supervision.

- Do not use the device in potentially explosive rooms or areas and do not install it there.
- Do not use the device in aggressive atmosphere.
- Only put up the device in an upright, stable position on firm ground.
- Let the device dry out after a wet clean. Do not operate it when wet.
- Do not use the device with wet or damp hands.
- Do not expose the device to directly squirting water.
- Do not cover the device during operation.
- Do not sit on the device.
- This device is not a toy. Keep away from children and animals. Do not leave the device unattended during operation.
- Check accessories and connection parts for possible damage prior to every use of the device. Do not use any defective devices or device parts.

- Ensure that all electric cables outside of the device are protected from damage (e.g. caused by animals). Never use the device if electric cables or the power connection are damaged!
- The mains connection must correspond to the specifications in the Technical annex.
- Insert the mains plug into a properly fused mains socket.
- Observe the device's power input, cable length and intended use when selecting extensions to the power cable. Completely unroll extension cables. Avoid electrical overload.
- Do not under any circumstances use the device if you detect damages on the mains plug or power cable. If the power cable is damaged, it must be replaced by the manufacturer, its service agent or similarly qualified persons in order to avoid a hazard. Defective power cables pose a serious health risk!
- Before carrying out maintenance, care or repair work on the device, remove the mains plug from the mains socket. Hold onto the mains plug while doing so.
- Switch the device off and disconnect the power cable from the mains socket when the device is not in use.
- When positioning the device, observe the minimum distances from walls and other objects as well as the storage and operating conditions specified in the Technical annex.
- Make sure that the air inlet and outlet are not obstructed.
- Make sure that the suction side is kept free of dirt and loose objects.
- Never insert any objects or limbs into the device.
- Do not remove any safety signs, stickers or labels from the device. Keep all safety signs, stickers and labels in legible condition.
- Only transport the device in an upright position with an emptied condensation tank or drain hose.
- Discharge the collected condensate before transport and storage. Do not drink it. Health hazard!
- Only use original spare parts, for otherwise safe and functional operation cannot be ensured.

Intended use

Only use the device as industrial dryer for drying and dehumidifying room air whilst adhering to the technical data and safety instructions.

Intended use comprises:

- drying and dehumidifying:
 - production plants, underground rooms
 - store rooms, archives, laboratories
 - rooms and areas after water damage caused by burst pipes or flooding
- keeping dry of:
 - instruments, devices, files
 - electric control devices, boiler plants, turbines and pipe systems in power plants
 - moisture-sensitive goods, loads, etc.

Foreseeable misuse

- Do not place the device on wet or flooded ground.
- Do not place any objects, e.g. clothing, on the device.
- Do not use the device out of doors.
- This device must not be used in wet rooms where splash water and permanently high humidity are to be expected due to use (e.g. bathrooms or laundry rooms).
- Do not make any unauthorised modifications, alterations or structural changes to the device.
- Any use other than the intended use is regarded as a reasonably foreseeable misuse.

Personnel qualifications

People who use this device must:

- be aware of the dangers that occur when working with electric devices in damp areas.
- have read and understood the instructions, especially the Safety chapter.

Maintenance tasks which require the housing to be opened must only be carried out by specialist companies for cooling and air-conditioning or by Trotec.

Residual risks



Warning of electrical voltage

Work on the electrical components must only be carried out by an authorised specialist company!



Warning of electrical voltage

Before any work on the device, remove the mains plug from the mains socket!
Do not touch the mains plug with wet or damp hands.
Hold onto the mains plug while pulling the power cable out of the mains socket.



Warning

Dangers can occur at the device when it is used by untrained people in an unprofessional or improper way!
Observe the personnel qualifications!



Warning

The device is not a toy and does not belong in the hands of children.



Warning

Risk of suffocation!
Do not leave the packaging lying around. Children may use it as a dangerous toy.

Note

Do not operate the device without an air filter inserted into the air inlet!
Without the air filter, the inside of the device will be heavily contaminated. This could reduce the performance and result in damage to the device.

Behaviour in the event of an emergency

1. Switch the device off.
2. Disconnect the device from the mains feed-in: Hold onto the mains plug while pulling the power cable out of the mains socket.
3. Do not reconnect a defective device to the mains.

Information about the device

Device description

The device uses the principle of condensation to automatically dehumidify rooms.

The fan sucks damp room air through the air inlet, the air filter, the evaporator and to the condenser located behind it. The air is cooled at the cold evaporator until it is below the dew point. Water vapour contained in the room air precipitates on the evaporator fins as condensation or rime. The dehumidified, cooled air is slightly warmed at the condenser and blown out again. The drier air thus conditioned mixes with the air in the room. The humidity in the room where the device is positioned is reduced as air constantly circulates through the device.

Depending on the air temperature and the relative humidity, the condensed water either drops into the condensation tray continuously or only during the defrost phases. The condensation is fed through a pressure-resistant pipe connection and out of the device by a condensate pump. To do so, a condensation drain hose is connected to the hose connector of the device and the condensate is drained.

The device has a control panel for operating and controlling the functions.

The device comes with a hot gas automatic defrost system. Here, the hot gas of the refrigerant circuit is used actively for fast and effective defrosting. This makes the device operate effectively even at temperatures below 15 °C.

Because of the heat radiation generated during operation, the room temperature may rise slightly.

Note

The condensate pump is fitted with a float switch. It completely switches off the condenser dryer when a critical filling level is reached in the condensation tray. Additionally, an acoustic signal will be emitted and the condensation tray indicator light is illuminated. After troubleshooting, the condenser dryer must be switched back on by hand.

Device depiction

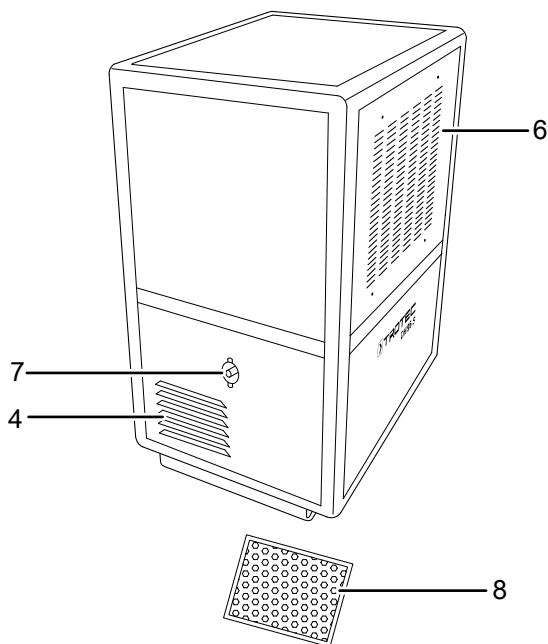
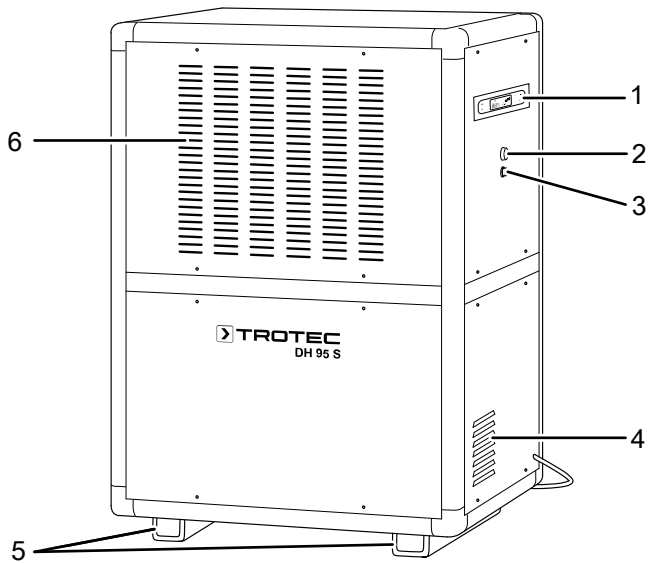

No.	Designation
1	Control panel
2	condensation tray indicator light with buzzer
3	button for draining residual water from the condensation tray
4	Air outlet
5	Feet
6	Air inlet with air filter
7	Condensation drain hose connection
8	Air filter

Transport and storage

Note

If you store or transport the device improperly, the device may be damaged.
Note the information regarding transport and storage of the device.

Transport

Always utilize the help of another person to transport the device. Do not try to transport the device without the help of another person. To lift the device, use a forklift or an elevating truck as appropriate.

Before transporting the device, observe the following:

- Wait until the condensate pump stops pumping condensate.
- Switch the device off.
- Hold onto the mains plug while pulling the power cable out of the mains socket.
- Drain the remaining condensate from the device and the condensation drain hose (see chapter Maintenance).
- Remove the condensation drain hose.
- Do not use the power cable to drag the device.

After transporting the device, proceed as follows:

- Set up the device in an upright position after transport.
- After having transported the device in horizontal position, leave the device to rest for 12 to 24 hours, so the refrigerant can accumulate within the compressor. Wait 12 to 24 hours before switching the device back on! Acting contrary might lead to compressor damage and a malfunctioning device. Any warranty claims will be voided in this case.

Storage

Before storing the device, proceed as follows:

- Drain the remaining condensate from the device and the condensation drain hose (see chapter Maintenance).
- Hold onto the mains plug while pulling the power cable out of the mains socket.

When the device is not being used, observe the following storage conditions:

- Store the device in a dry location and protected from frost and heat.
- If required, use a cover to protect the device from invasive dust.
- Place no further devices or objects on top of the device to prevent it from being damaged.

Assembly and start-up

Scope of delivery

- 1 x device
- 1 x Condensation drain hose
- 1 x manual

Unpacking the device

1. Open the cardboard box and take the device out.
2. Completely remove the packaging.
3. Fully unwind the power cable. Make sure that the power cable is not damaged and that you do not damage it during unwinding.

Start-up

When positioning the device, observe the minimum distance from walls or other objects as described in the chapter Technical annex.

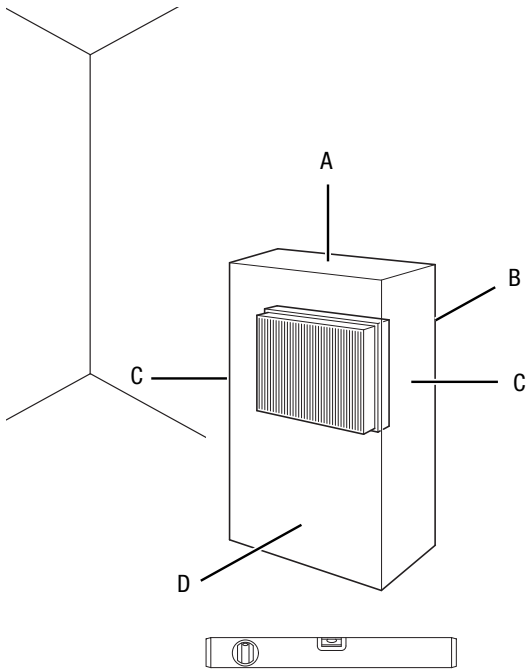

- Before restarting the device, check the condition of the power cable. If there are doubts as to the sound condition, contact the customer service.
- Only put up the device in an upright, stable position on firm ground.
- Do not create tripping hazards when laying the power cable or other electric cables, especially when positioning the device in the middle of the room. Use cable bridges.
- Make sure that extension cables are completely unrolled.
- When positioning the device, keep a sufficient distance to heat sources.
- Make sure that no curtains or other objects interfere with the air flow.

- When positioning the device, particularly in wet areas, secure it locally with an RCD (residual current device) which complies with the respective regulations.

Inserting the air filter

Note

Do not operate the device without an air filter inserted into the air inlet!

Without the air filter, the inside of the device will be heavily contaminated. This could reduce the performance and result in damage to the device.

- Make sure that the air filters are installed before switching the device on.

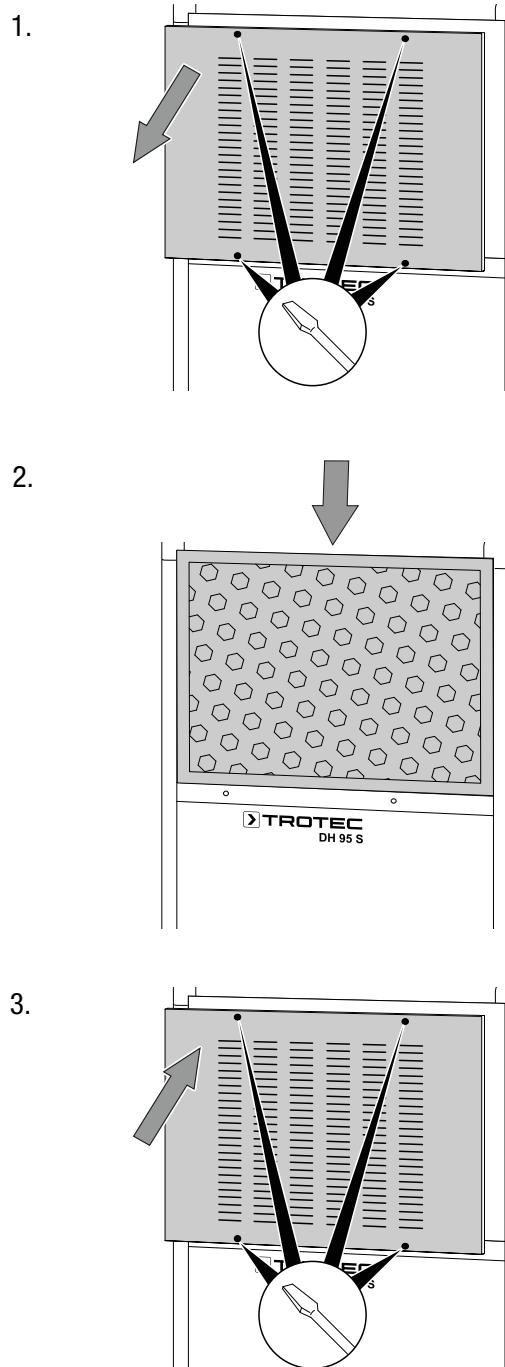

Positioning the condensation drain hose

- ✓ A suitable hose (diameter: 8 mm) is ready for use.
 - ✓ The device is switched off.
1. Connect the condensation drain hose to the condensation hose connection (7) at the device.

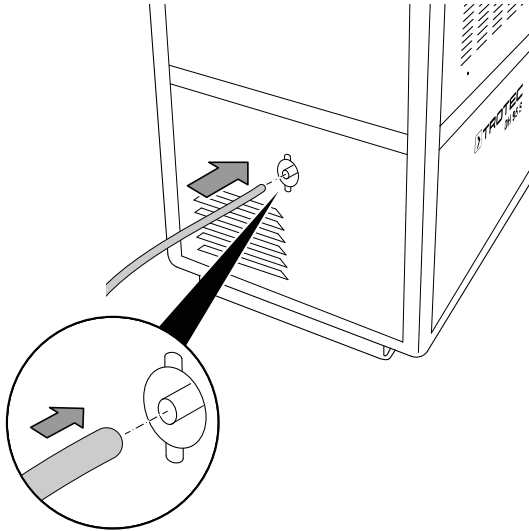

- ⇒ Position the end of the condensation drain hose above a water drain. For larger distances, a longer hose of the same type can also be used.

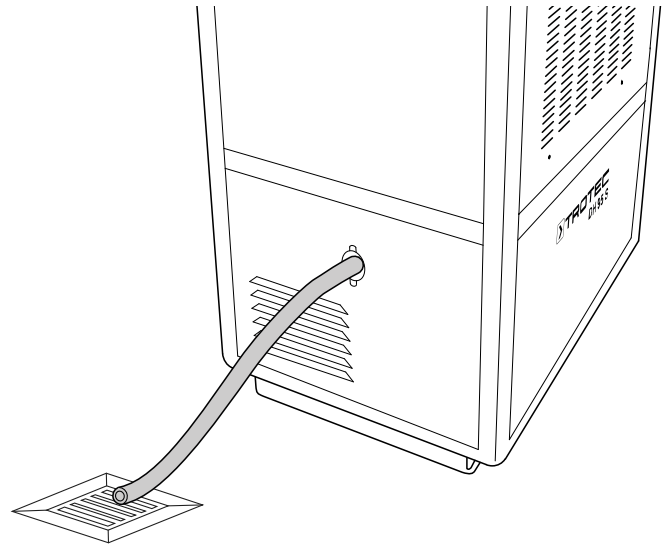

2. Make sure that the condensation drain hose is properly connected to the device and free of damage.
3. Depending on the application, position the end of the condensation drain hose as follows:
 - ⇒ Place a sufficiently dimensioned container (at least 90 litres) beside the device and insert the hose end. Check the filling level of the container regularly.

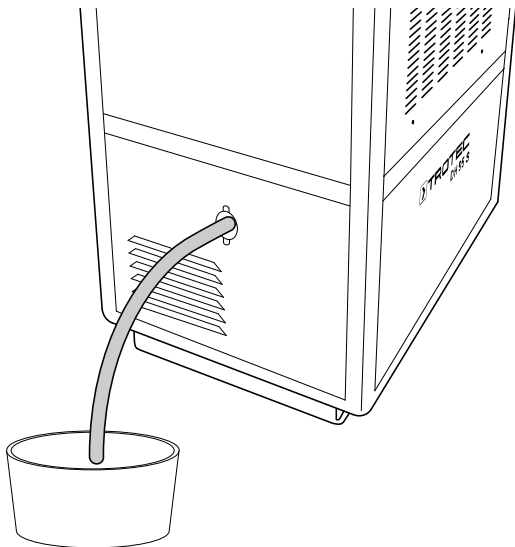

Operation

- Avoid open doors and windows.
- After being switched on, the device operates fully automatically.
- The fan runs permanently until the set nominal value is reached or the device switched off.

Control panel DH 95 S

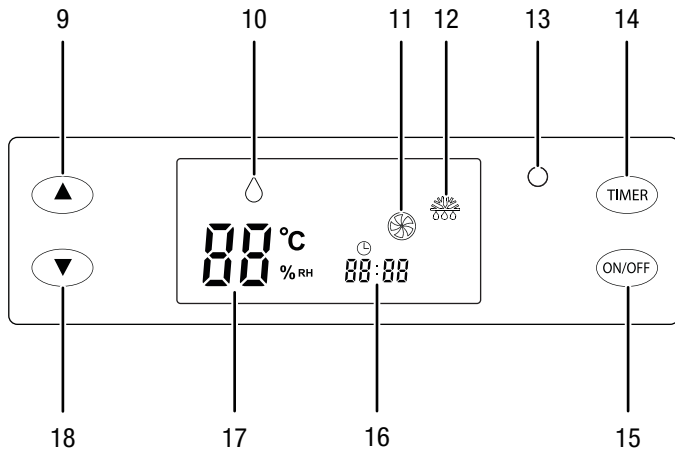

No.	Designation	Meaning
9	Increase value button	For setting the relative room humidity For setting the number of hours for the timer function
10	Dehumidification symbol	Dehumidification mode active
11	Fan symbol	Fan active
12	Automatic defrost symbol	Automatic defrosting active
13	Operating light	Illuminated during operation.
14	TIMER button	Switches the timer function on or off.
15	ON/OFF button	Power button: Switching the device on or off
16	Segment display for the selected operating time	Indication of the number of hours until automatic switch-on or switch-off if the timer is programmed
17	Segment display	Indicates the selected relative humidity in per cent. Indicates CO for continuous operation.
18	Decrease value button	For setting the relative room humidity For setting the number of hours for the timer function

Switching the device on

Once you have completely installed the device as described in the chapter Assembly and start-up, you can switch it on.

1. Press the *ON/OFF* button (15).
⇒ The device is switched on.
⇒ The operating light (13) is illuminated.
2. Press the *ON/OFF* button (15) again to switch the device off.

The device switches off automatically when the condensation tray is full. The condensation tray indicator light (2) lights up and the buzzer emits an acoustic signal.

Setting the desired room humidity

The desired relative room humidity can be preselected.

1. Press the *increase value* (9) or *decrease value* button (18) to set the desired relative room humidity. Setting is possible in the range between 30 % and 90 %.
⇒ The desired relative humidity level is indicated on the segment display (17).

The device keeps running until reaching the desired relative room humidity. Once the desired relative room humidity is exceeded, the compressor and fan switch back on.

Setting continuous operation

The device dehumidifies the air constantly and regardless of the relative room humidity.

The desired relative room humidity cannot be adjusted in this operating mode.

1. Press the *decrease value* button (18) until *CO* is displayed by the segment display (17).
⇒ *Continuous operation* mode is selected.

Setting the timer

The timer has the following functionality:

- automatic switch-off upon expiry of a preset number of hours.

Note

Do not leave the operating device unattended in a freely accessible room with an activated timer.

Automatic switch-off

- ✓ The device is switched on.
- 1. Press the *TIMER* button (14).
 - ⇒ The segment display for the *selected operating time* (16) indicates the number of hours until automatic switch-off.
- 2. Repeatedly press the *TIMER* button (14) until the desired number of hours is indicated in the segment display for the *selected operating time* (16).
 - ⇒ The timer setting equals the desired number of hours.
 - ⇒ The device switches off after the set period of time.

Automatic defrosting

At low ambient temperatures, ice may form at the evaporator during dehumidification. The device will then carry out an automatic defrost. Dehumidification is briefly interrupted during defrosting. The fan keeps running.

The *automatic defrost* symbol (12) is displayed.

The duration of the defrost process can vary. Do **not** switch off the device during automatic defrost. Do **not** remove the mains plug from the mains socket.

- Automatic defrosting is interrupted once you actuate the *ON/OFF* button (15) or either the *increase value* button (9) or the *decrease value* button (18).

Shutdown



Warning of electrical voltage

Do not touch the mains plug with wet or damp hands.

- Switch off the device.
- Hold onto the mains plug while pulling the power cable out of the mains socket.
- If necessary, remove the condensation drain hose and any residual fluid from it.
- Clean the device according to the Maintenance chapter.
- Store the device according to the Transport and storage chapter.

Errors and faults

The device has been checked for proper functioning several times during production. If malfunctions occur nonetheless, check the device according to the following list.

Note

The device is equipped with a safety timer. Switch-ons and switch-offs can be delayed by up to 3 minutes.

The device does not start:

- Check the power connection.
- Check the power cable for damages.
- Check the on-site fusing.
- Check the filling level of the condensation tray and empty it, if necessary. The indicator light for the condensation tray (2) must not be illuminated and the buzzer must not emit an acoustic signal.
- Have the electrics checked by a specialist company for cooling and air-conditioning or by Trotec.

The device is running, but there is no formation of condensate:

- Check whether the condensation drain hose is positioned correctly.
- Check the room temperature. Observe the device's permissible operating range according to the technical data.
- Ensure that the relative humidity complies with the technical data.
- Check the preselected desired humidity level. The humidity in the room where the device is positioned must be at least 3 % higher than the target value. If necessary, reduce the set relative humidity.
- Check the condensate pump for proper functioning or unusual vibrations and sounds. Remove external dirt (see chapter Maintenance).
- Check both air filters for dirt. If necessary, clean or replace the air filters (see chapter Maintenance).
- Check the exterior of the condenser and the condensate pump for dirt (see chapter Maintenance). If the inside of the device is dirty, have it cleaned by a specialist company or by Trotec.

The device is loud or vibrates:

- Check whether the device is set up in a stable and upright position.

The device gets very warm, is loud or loses power:

- Check the air inlets and air filters for dirt. Remove external dirt.
- Check the inside of the device and especially the fan, the fan housing, the evaporator, the condenser and the condensate pump for external dirt (see chapter Maintenance). If the inside of the device is dirty, have it cleaned by a specialist company for cooling and air-conditioning or by Trotec.

Your device still does not operate correctly after these checks?

Please contact the customer service. If necessary, bring the device to a specialist company for cooling and air-conditioning or to Trotec for repair.

Error codes

The following error messages can be displayed on the segment display:

Error code	Cause	Remedy
E1	Refrigerant filling level too low	Please contact the customer service.
E2	Error message of the temperature sensor	Switch the device off and contact the customer service.
E3	Error message of the humidity sensor	Use the drying unit at a humidity level which complies with the technical data.
E5	Error message of the sensor in the refrigerant circuit	Switch the device off and contact the customer service.

Maintenance

Maintenance intervals

Maintenance and care interval	before every start-up	as needed	at least every 2 weeks	at least every 4 weeks	at least every 6 months	at least annually
Empty the condensate pump, condensation tray and/or condenser dryer		X				
Check air inlets and outlets for dirt and foreign objects and clean if necessary	X			X		
Clean the exterior		X				X
Visually check the inside of the device for dirt		X		X		
Check air inlet grid(s) and air filter(s) for dirt and foreign objects and clean or replace if necessary	X		X			
Replace the air filter(s)					X	
Check for damage	X					
Check the attachment screws		X				X
Test run						X

Maintenance and care log

Device type:

Device number:

Maintenance and care interval	1	2	3	4	5	6	7	8	9	10	11	12	13	14	15	16
Check air inlets and outlets for dirt and foreign objects and clean if necessary																
Clean the exterior																
Visually check the inside of the device for dirt																
Check air inlet grid(s) and air filter(s) for dirt and foreign objects and clean or replace if necessary																
Replace the air filter(s)																
Check for damage																
Check the attachment screws																
Test run																
Comments																

1. Date:	2. Date:	3. Date:	4. Date:
Signature:	Signature:	Signature:	Signature:
5. Date:	6. Date:	7. Date:	8. Date:
Signature:	Signature:	Signature:	Signature:
9. Date:	10. Date:	11. Date:	12. Date:
Signature:	Signature:	Signature:	Signature:
13. Date:	14. Date:	15. Date:	16. Date:
Signature:	Signature:	Signature:	Signature:

Activities required before starting maintenance



Warning of electrical voltage

Do not touch the mains plug with wet or damp hands.

- Switch the device off.
- Hold onto the mains plug while pulling the power cable out of the mains socket.



Warning of electrical voltage

Tasks which require the device to be opened must only be carried out by authorised specialist companies or by Trotec.

Cleaning the housing

Clean the housing with a soft, damp and lint-free cloth. Make sure that no moisture enters the housing. Protect electrical components from moisture. Do not use any aggressive cleaning agents such as cleaning sprays, solvents, alcohol-based or abrasive cleaners to dampen the cloth.

Visual inspection of the inside of the device for dirt

1. Remove the air filter.
2. Use a torch to illuminate the openings of the device.
3. Check the inside of the device for dirt.
4. If you see a thick layer of dust, have the inside of the device cleaned by a specialist company for cooling and air-conditioning or by Trotec.
5. Put the air filter back in.

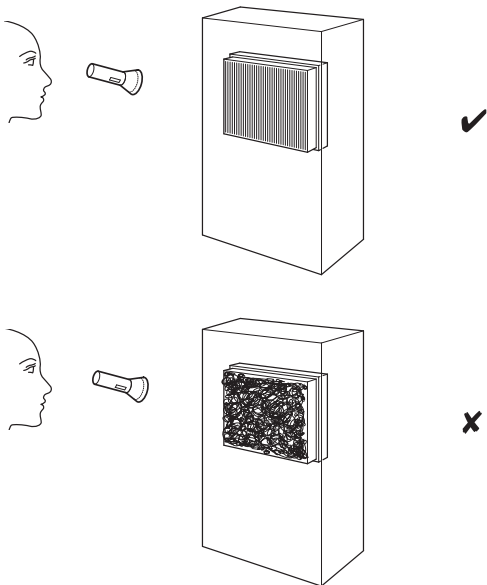

Refrigerant circuit

- The entire refrigerant circuit is a maintenance-free, hermetically sealed system and may only be maintained or repaired by specialist companies for cooling and air-conditioning or by Trotec.

Cleaning the air filter

1. Remove the two air filters from the device.

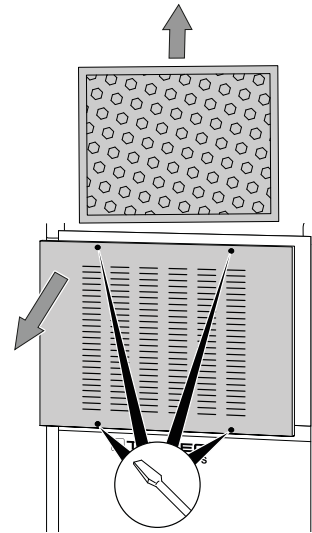

2. Clean the filters using a slightly damp, soft, lint-free cloth. If the filters are heavily contaminated, clean them with warm water mixed with a neutral cleaning agent.

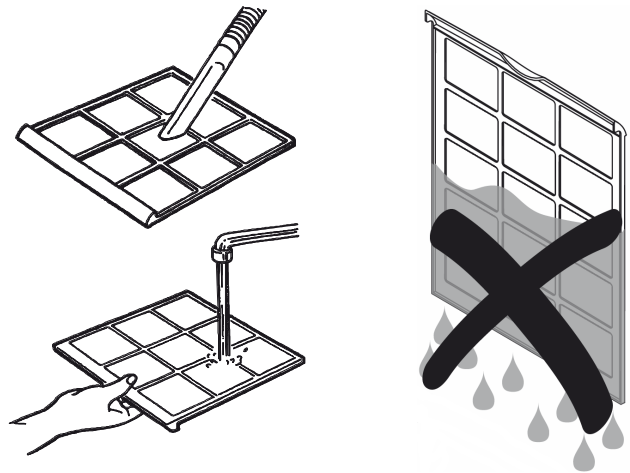

3. Allow the filters to dry completely. Do not put any wet filters into the device!
4. Reinsert the air filters into the device.

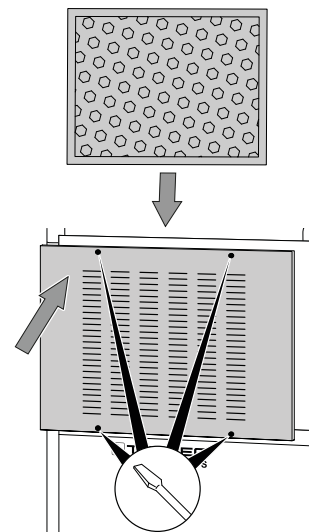

Technical annex

Technical data

Parameter	Value
Model	DH 95 S
Dehumidification performance at 30 °C and 80 % RH	130 l / 24 h
Air flow rate	1100 m ³ /h
Operating range (temperature)	5 °C to 32 °C
Operating range (relative humidity)	30 % to 90 % RH
Pressure suction side	1.65 MPa
Pressure outlet side	3.1 MPa
Mains connection	220-240 V / 50 Hz
Power consumption, max.	2.77 kW
Nominal current	13.2 A
Refrigerant	R-410A
Amount of refrigerant	1450 g
GWP factor	2088
CO ₂ equivalent	3.03 t
Sound pressure level (at a distance of 1 m)	62 dB(A)
Type of protection	IPX0
Dimensions (length x width x height)	465 x 600 x 910 mm
Minimum distance to walls and other objects	A: top: 50 cm B: rear: 50 cm C: side: 50 cm D: front: 50 cm
Weight	65 kg

Wiring diagram

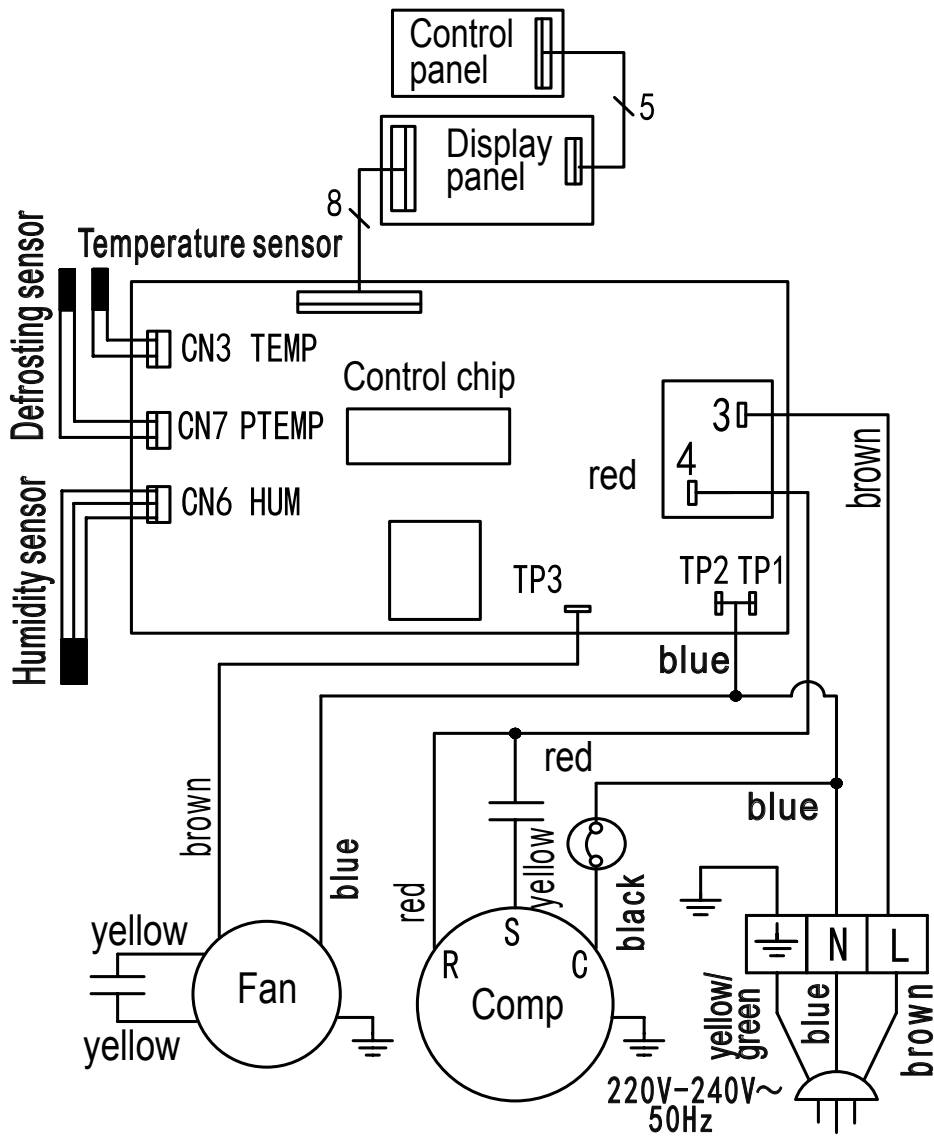

Overview and list of spare parts

Note: The position numbers of the spare parts differ from those describing the positions of the components mentioned in these instructions.

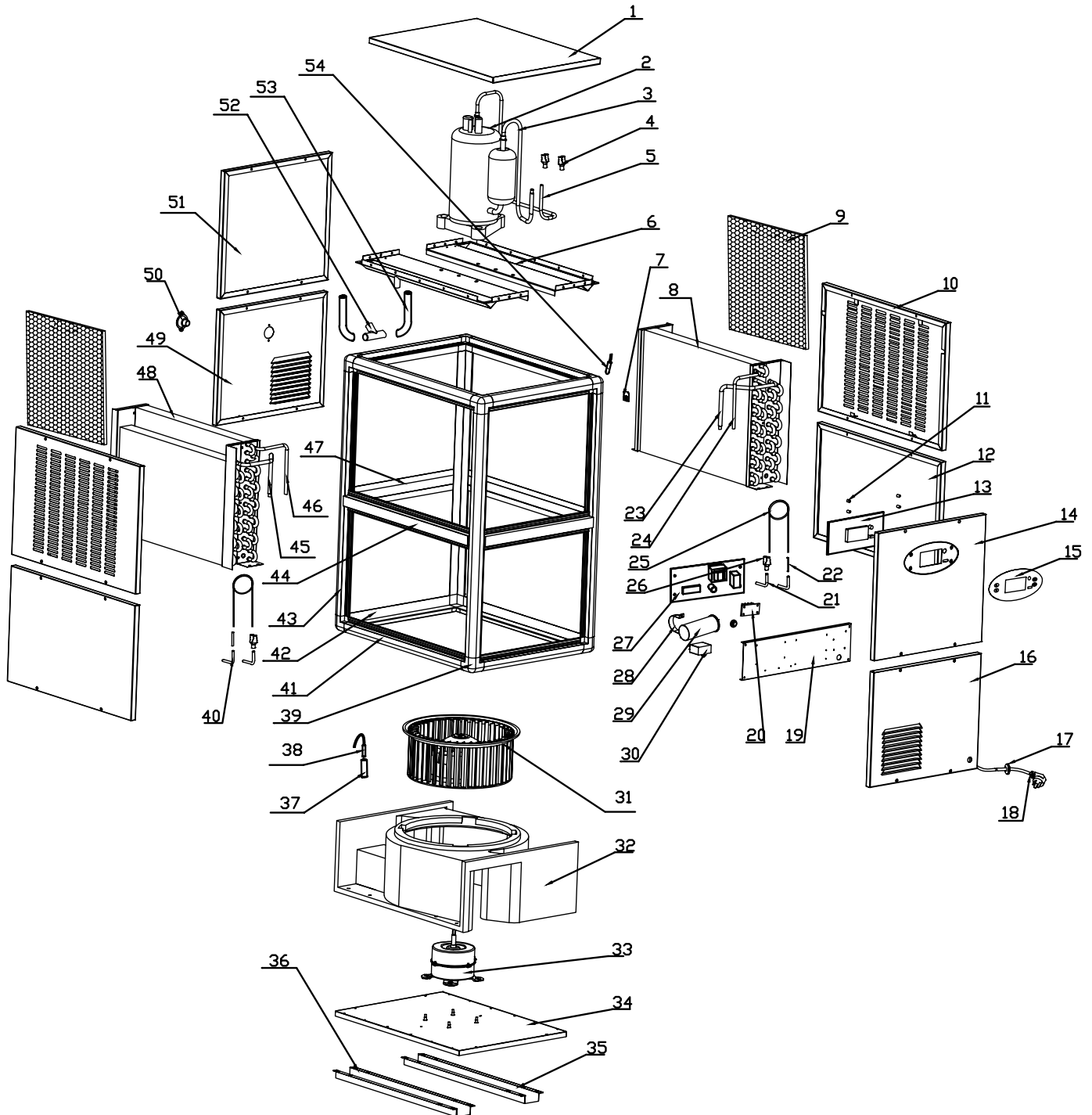

No.	Spare part	No.	Spare part	No.	Spare part
1	top cover	19	mounted panel	37	temperature sensor pipe
2	compressor	20	connection	38	hot gas sensor
3	low pressure pipe a	21	inlet tube	39	connector
4	three ways tube	22	process tube I	40	distributor
5	high pressure pipe I	23	low pressure pipe III	41	cross bar I
6	middle panel	24	high pressure pipe III	42	cross bar II
7	humidity sensor	25	capillary tube	43	upright pst
8	evaporator II and condenser	26	filter	44	middle support I
9	filter net	27	main control board	45	low pressure pipe II
10	air inlet	28	capacitor hoop	46	high pressure pipe II
11	separated post Ø 8x15	29	capacitor (compressor)	47	middle support II
12	front panel	30	capacitor (fan)	48	evaporator I and condenser
13	displayer	31	fan blade	49	lower side panel
14	upper right side panel	32	scroll housing	50	water out connector
15	film switch	33	motor	51	upper left side panel
16	lower right side panel	34	pedestal	52	three way connector
17	Ø 12 wire protector	35	stand II	53	Ø 20x16 water pipe
18	wire	36	stand I	54	temperature sensor

Disposal

Always dispose of packing materials in an environmentally friendly manner and in accordance with the applicable local disposal regulations.



The icon with the crossed-out waste bin on waste electrical or electronic equipment stipulates that this equipment must not be disposed of with the household waste at the end of its life. You will find collection points for free return of waste electrical and electronic equipment in your vicinity. The addresses can be obtained from your municipality or local administration. You can also find out about other return options that apply for many EU countries on the website <https://hub.trotec.com/?id=45090>. Otherwise, please contact an official recycling centre for electronic and electrical equipment authorised for your country.

The separate collection of waste electrical and electronic equipment aims to enable the re-use, recycling and other forms of recovery of waste equipment as well as to prevent negative effects for the environment and human health caused by the disposal of hazardous substances potentially contained in the equipment.

The device is operated with fluorinated greenhouse gas, which can be dangerous for the environment and contribute to global warming when emitted to the atmosphere.

Further information is provided on the nameplate.

Dispose of the refrigerant appropriately and according to the national regulations.

Declaration of conformity

Declaration of conformity in accordance with the EC Machinery Directive 2006/42/EC, Annex II, Part 1, Section A

We – Trotec GmbH – declare in sole responsibility that the product designated below was developed, constructed and produced in compliance with the requirements of the EC Machinery Directive in the version 2006/42/EC.

Product model / Product: DH 95 S
Product type: condenser dryer
Year of manufacture as of: 2022

Relevant EU directives:

- 2012/19/EU
- 2014/30/EU

Applied harmonised standards:

- EN 55014-1:2017/A11:2020
- EN 60335-1:2012/A15:2021
- EN 60335-2-40:2003
- EN 60335-2-40:2003/A1:2006
- EN 60335-2-40:2003/A2:2009
- EN 60335-2-40:2003/A11:2004
- EN 60335-2-40:2003/A12:2005
- EN 60335-2-40:2003/A13:2012

Applied national standards and technical specifications:

- EN IEC 61000-3-2:2019
- EN IEC 61000-3-11:2019
- EN 55014-2:2015
- EN 60335-1:2012/A1:2019
- EN 60335-1:2012/A2:2019
- EN 60335-1:2012/A14:2019
- EN 62233:2008

Manufacturer and name of the authorised representative of the technical documentation:

Trotec GmbH
Grebbeener Straße 7, D-52525 Heinsberg
Phone: +49 2452 962-400
E-mail: info@trotec.de

Place and date of issue:
Heinsberg, 05.07.2022



Joachim Ludwig, Managing Director

Trotec GmbH

Grebener Str. 7
D-52525 Heinsberg

☎ +49 2452 962-400

☎ +49 2452 962-200

✉ info@trotec.com

www.trotec.com