

EN

ORIGINAL INSTRUCTIONS
FOG AND FLUE GAS SIMULATOR



Table of contents

Information on the use of these instructions 2

Safety 2

Information about the device..... 5

Transport and storage..... 6

Operation 7

Available accessories 9

Errors and faults..... 10

Maintenance and repair 10

Disposal 12

EU Declaration of Conformity..... 13

Information on the use of these instructions

Symbols

 **Warning of electrical voltage**
This symbol indicates dangers to the life and health of persons due to electrical voltage.

 **Warning of flammable substances**
This symbol indicates dangers to the life and health of persons due to flammable substances.

 **Warning of hot surface**
This symbol indicates dangers to the life and health of persons due to hot surface.

 **Warning**
This signal word indicates a hazard with an average risk level which, if not avoided, can result in serious injury or death.

 **Caution**
This signal word indicates a hazard with a low risk level which, if not avoided, can result in minor or moderate injury.

Notice
This signal word indicates important information (e.g. material damage), but does not indicate hazards.

 **Info**
Information marked with this symbol helps you to carry out your tasks quickly and safely.

 **Follow the manual**
Information marked with this symbol indicates that the instructions must be observed.

You can download the current version of these instructions via the following link:

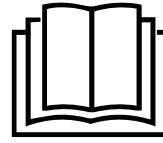

FS 200



<https://hub.trotec.com/?id=43769>

Safety

Read this manual carefully before starting or using the device. Always store the manual in the immediate vicinity of the device or its site of use.

 **Warning**
Read all safety warnings and all instructions. Failure to follow the warnings and instructions may result in electric shock, fire and/or serious injury.
Save all warnings and instructions for future reference.

This appliance can be used by children aged from 8 years and above and persons with reduced physical, sensory or mental capabilities or lack of experience and knowledge if they have been given supervision or instruction concerning use of the appliance in a safe way and understand the hazards involved. Children shall not play with the appliance. Cleaning and user maintenance shall not be done by children without supervision.

- Do not use the device in potentially explosive rooms or areas and do not install it there.
- Do not use the device in an aggressive atmosphere.
- Protect the device from permanent direct sunlight.
- Do not remove any safety signs, stickers or labels from the device. Keep all safety signs, stickers and labels in legible condition.
- Do not open the device.

Intended use

Only use the device for generating fog. Only use the device within the framework of the technical data. Any use other than the intended use is regarded as misuse.

Reasonably foreseeable misuse

Do not use the device in potentially explosive areas. Do not use the device underwater. Never use the device on persons or animals. Do not use fog fluid that is not approved in the technical data. Other fog fluids can damage the device. Any unauthorised changes, modifications or alterations to the device are forbidden.

Personnel qualification

People who use this device must:

- have read and understood the instructions, especially the Safety chapter.

Personal protective equipment



Wear protective gloves.

They protect your hands from burns, crushing injuries and skin abrasions.



Wear respiratory protection.

When working with the device in closed rooms and when using the flue gas chamber always wear respiratory protection.

Safety signs and labels on the device

Notice

Do not remove any safety signs, stickers or labels from the device. Keep all safety signs, stickers and labels in legible condition.

The following safety signs and labels are attached to the device:

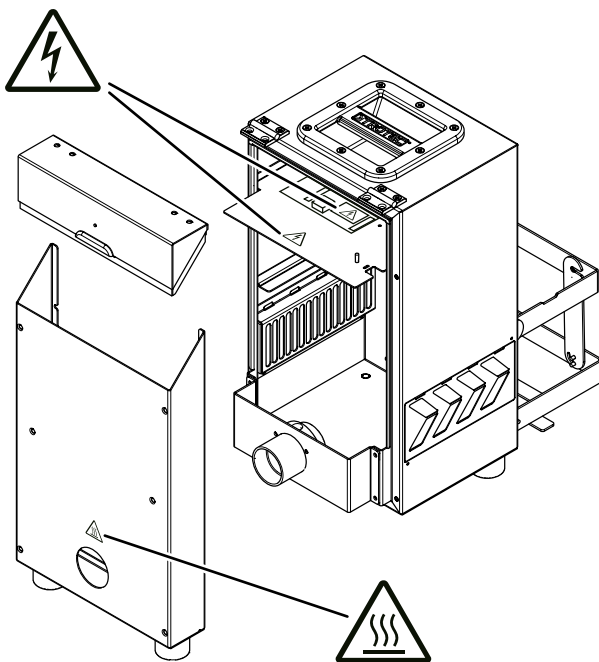

Residual risks



Warning of electrical voltage

There is a risk of a short-circuit due to liquids penetrating the housing!

Do not immerse the device and the accessories in water. Make sure that no water or other liquids can enter the housing.



Warning of electrical voltage

Work on the electrical components must only be carried out by an authorised specialist company!



Warning of electrical voltage

Before any work on the device, remove the mains plug from the mains socket!

Do not touch the mains plug with wet or damp hands. Hold onto the mains plug while pulling the power cable out of the mains socket.



Warning of hot surface

Particularly at the cover the flue gas chamber becomes very hot! Always wear protective gloves when working with the flue gas chamber.



Warning of hot surface

During operation keep sufficient distance to the fog or smoke outlet. Hot steam emerges, there is a burn hazard.



Warning of flammable substances

Hazard due to flammable substances. When burning a smoke bomb, keep a safety distance of at least 3 m to the flue gas chamber. Do not dispose of the spent smoke bomb until it has cooled down completely!



Warning

Health hazard due to unsuitable fog fluids! Using fog fluids from other manufacturers may result in the formation of harmful decomposition products. Only operate the device with the original FluiTect fog concentrate from Trotec. This product does not produce any harmful decomposition products.



Warning

Risk of suffocation! Do not leave the packaging lying around. Children may use it as a dangerous toy.



Warning

The device is not a toy and does not belong in the hands of children.

**Warning**

Dangers can occur at the device when it is used by untrained people in an unprofessional or improper way! Observe the personnel qualifications!

**Caution**

Keep a sufficient distance from heat sources.

**Warning**

Let the turbine coast for approx. 20 seconds on the medium level to transport remaining fluids from the device. The fluid pump must be switch off completely to prevent the pump from running dry!

**Warning**

Do not use the device without air filter, for otherwise the turbine could be damaged due to penetrating foreign objects.

Notice

Directly behind the outlet opening the emerging fumes are very hot and, if handled incorrectly, this could result in the hose material melting or being damaged otherwise!

In order to avoid heat accumulation in the hose directly behind the fog outlet opening, the first metre of hose must not be bent, but instead be laid in a straight line from the generator!

Notice

Do not operate the device without fog fluid!
Without fog fluid, the pump can be damaged.

Notice

Only use FluiTect fog concentrate from Trotec.
Other fog fluids can damage the device.

Notice

To prevent damages to the device, do not expose it to extreme temperatures, extreme humidity or moisture.

Notice

Do not use abrasive cleaners or solvents to clean the device.

Information about the device

Device description

The device serves the purpose of creating artificial fog by means of fog fluid.

The fog fluid is sucked in by a pump and then heated. With the integrated high-performance turbine and the thus producible pressure the fog can be introduced both over long distances (e. g. sewage pipes, large halls) and in installations with high counter-pressure (e. g. flat-roofed constructions). Possible application purposes are for example leak detection, fire brigade training exercises, quality inspections and tightness tests.

Device depiction

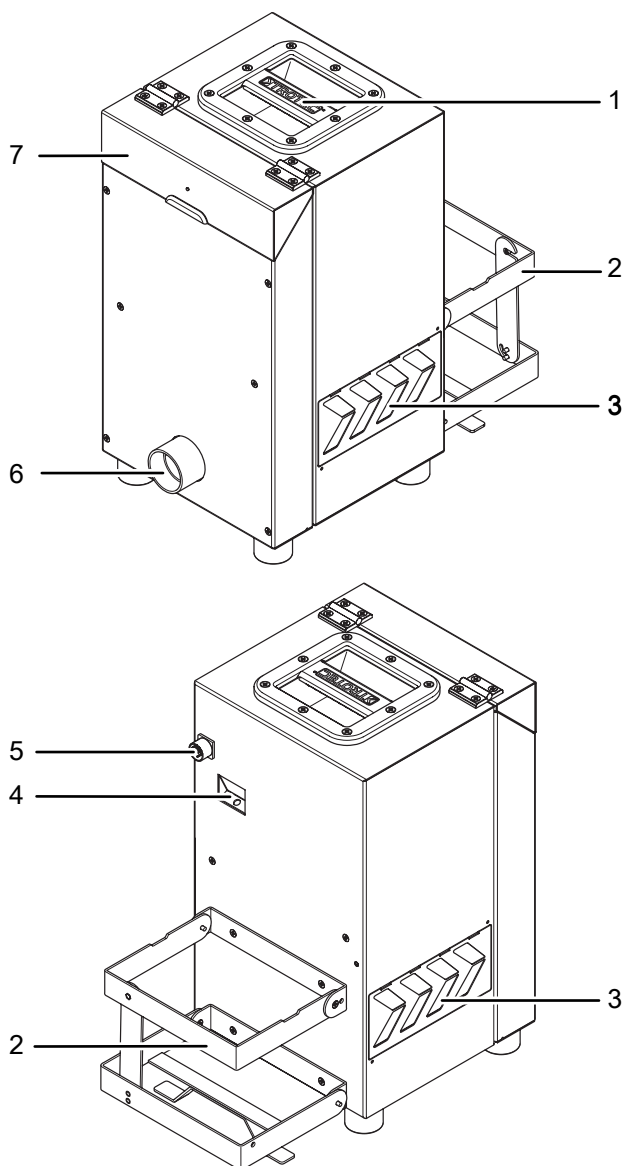

No.	Designation
1	Transport handle
2	Holder for fog fluid canister
3	Air vent with filter
4	Connection for fog fluid canister
5	Power cable
6	Fog transport hose connection
7	Control panel with protective flap

Control panel

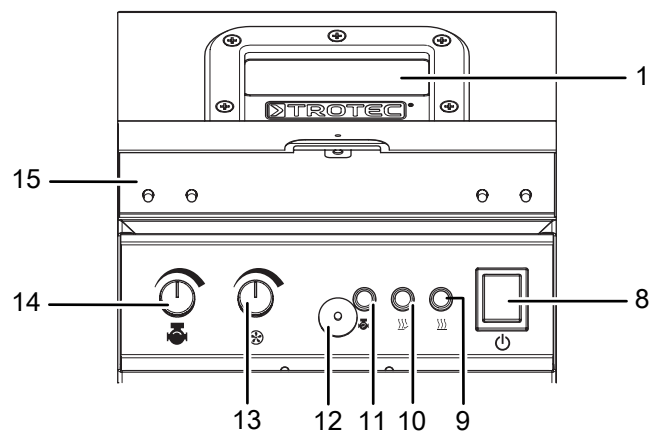

No.	Designation	Meaning
8	<i>On/off switch</i>	For switching the device on or off
9	<i>Heating-up phase indicator</i>	Is illuminated when the device heats up
10	<i>Heating ready indicator</i>	Is illuminated when the device has heated up and is ready for operation
11	<i>Pump indicator</i>	Is illuminated if the pump is active and fog emerges
12	Magnetic lock for the protective flap	Keeps the protective flap (15) closed
13	Controller for the turbine	Controls the turbine speed
14	Controller for the pump	Controls the flow rate of the pump
15	Protective flap	Protects the elements of the control panel against inadvertent adjustment

Technical data

Parameter	Value
Model	FS 200
Weight without fluid	14 kg
Dimensions (height x width x depth)	465 x 253 x 310 mm
Evaporator power	1,500 W
Fan turbine power	1,600 W
Power consumption, max.	3,100 W
Supply voltage	230 V / 50 Hz
Type of protection	IP 54
Air flow rate	Approx. 68 l/s (approx. 245 m ³ /h)
Approved fluid	Trotec FluiTect fog concentrate
Fluid quantity	5 l
Fluid consumption at maximum output	100 ml/min
Fluid consumption at continuous fog output	30 ml/min
Fogging time at max. stage	Approx. 210 seconds of continuous fog output
Heating time	After approx. 7 minutes
Operating conditions	5 °C to 45 °C with less than 80 % RH
Storage conditions	5 °C to 45 °C with less than 80 % RH

Scope of delivery

- 1 x Device FS 200
- 1 x 5 m fog transport hose (plastic DN 38)
- 1 x Connector with GEKA coupling
- 1 x 5 l of Fluitect fog fluid in canister
- 1 x Connecting hose fluid canister
- 1 x Quick guide

Optional accessories

- Aluminium end connectors for poly flat roof
- Aluminium end connectors for flat bitumen roof
- Fluitect fog fluid (5 l in canister)
- Flue gas chamber and coloured smoke cartridges for fire simulation
- Transport case (trolley)

Transport and storage

Notice

If you store or transport the device improperly, the device may be damaged.
Note the information regarding transport and storage of the device.

Transport

Before transporting the device, proceed as follows:

- Before transporting the device, remove the fluid canister, see chapter Exchanging the canister.
- Transport the canister separately.
- Fold the canister holder up for transport, see chapter Folding the holder up.
- Only transport the device by use of the transport handle.

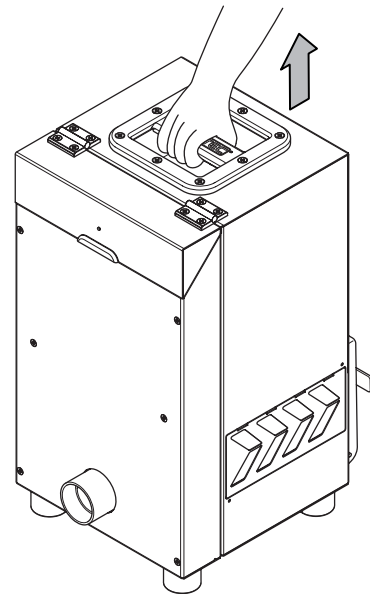

Folding the holder up

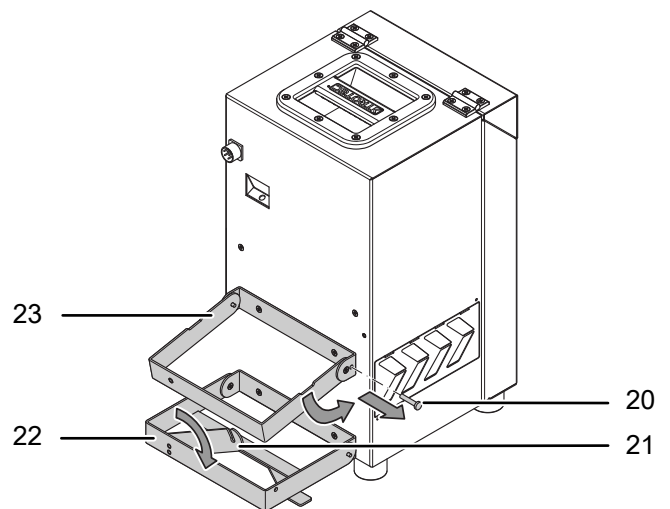

1. Remove the safety bolt (20).
2. Fold the holder's stabiliser (21) in until it is located at the same height as the lower holder (22).

3. Fold down the upper holder (23) until it abuts the housing.

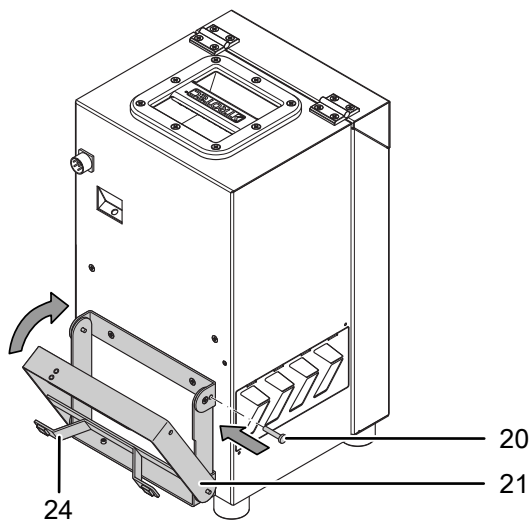

4. Fold up the lower holder (22) until it abuts the housing as well.
5. Then put the safety bolt (20) back to fix the holder in place.
6. Wind the power cable up on the foot (24).

Storage

When the device is not being used, observe the following storage conditions:

- dry and protected from frost and heat
- protected from dust and direct sunlight
- with a plastic cover to protect it from invasive dust, if necessary
- at the temperature specified in the technical data
- The ground is protected against possibly dripping fluid residues.

Operation

Safety instructions for operation



Warning

Health hazard due to unsuitable fog fluids!
Using fog fluids from other manufacturers may result in the formation of harmful decomposition products. Only operate the device with the original FluiTect fog concentrate from Trotec. This product does not produce any harmful decomposition products.

Notice

When using fog fluids from other manufacturers, residues may form during evaporation. These residues can clog the capillaries of the heating module and damage the heating element. Such damage will void the warranty.

Positioning

The location for the fog generator has to meet the following requirements:

- sufficiently dimensioned
- solid, incombustible ground insensitive to heat
- vibration-free
- minimum distance of 2 m to combustible or heat-sensitive objects
- sufficient supply of fresh air

Information regarding the operation with emergency power units:

- The applied emergency power generators must be asynchronous, feature a nominal capacity of min. 4 kVA (230 V) and be checked for proper functioning.
- Before connecting the fog generator, the emergency power unit must be brought to operating temperature while unloaded (depending on the device approx. 1 to 2 min). Only after this is completed can failure-free operation be guaranteed.

Information regarding the use of extension cables:

- Ensure a high quality of the cable.
- The cable's cross-section should amount to at least 2.5 mm².
- All extension cables must have been rolled off completely.

Folding holder out

Folding the holder out works just as folding it up, only in reverse order (see "Folding the holder up").

Connecting the fog transport hose

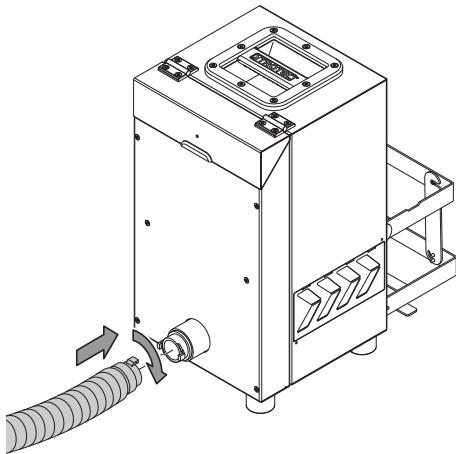

1. Connect one end of the fog transport hose to the connection coupling at the device.
2. Connect the other end of the fog transport hose with the object to be tested.

Connecting the canister

A.

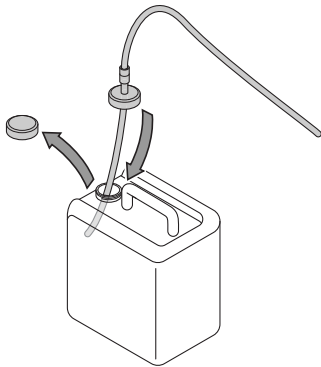

B.

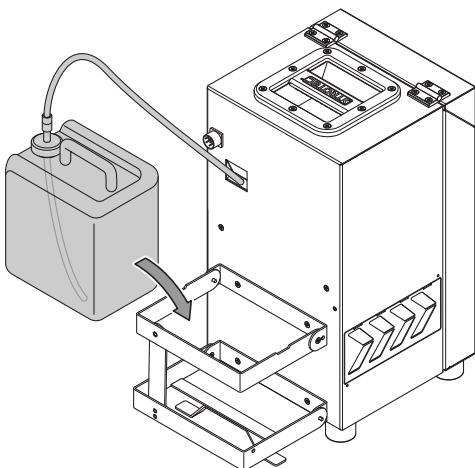

Switching the device on

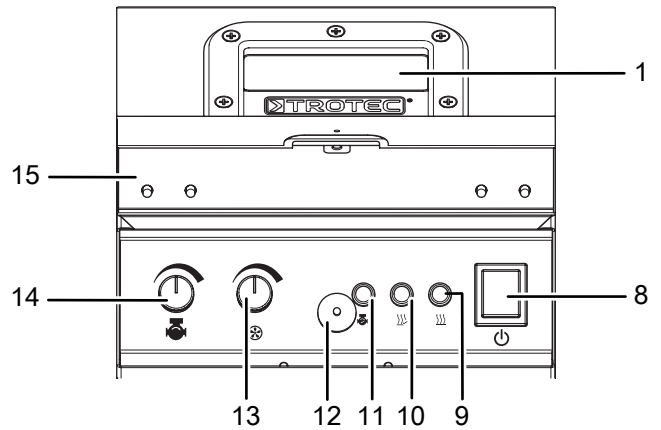

1. Check the canister's filling level and exchange it, if required (see the "Exchanging the canister" chapter).
2. Unscrew the sealing cap on the canister by a half-turn to avoid the creation of a vacuum.
3. Check that the connection hose is correctly connected to the connection at the canister lid.
 - ⇒ The hose connection must be fully engaged in the lid's connection! If not properly connected, air will be sucked into the system, which can lead to a malfunction or even defect of the fluid pump.
4. Plug the power cable into a sufficiently fused socket.
5. Press the on/off switch (8).
 - ⇒ The switch lights up in green.
6. Set the pump controller (14) to 8 o'clock position.
 - ⇒ The *heating-up phase* (9) indicator lights up in red.
 - ⇒ The heating-up phase of the device starts.
7. Wait for approx. 7 minutes until the heating-up phase is completed.
 - ⇒ The *heating ready* (10) indicator is illuminated in green, showing that the device is ready for operation.
8. Turn the turbine controller (13) to the left stop (OFF).
 - ⇒ It must click into place noticeably.
9. Turn the pump controller (14) to the right stop (MAX).
 - ⇒ The fluid pump now operates at full power for a few seconds.
 - ⇒ The capillary tube system is completely filled with fluid and fog starts emerging from the connection of the fog transport hose (6).
10. Once fog starts to emerge, turn the turbine controller (13) and the pump controller (14) to 10 o'clock position.
11. Use the pump controller (14) to adjust the desired amount of fog.
 - ⇒ Fog starts being emerging from a position of approx. 9 o'clock and the *pump* (11) indicator is illuminated in blue.
12. Gradually rotate the pump controller (14) clockwise until fog is conveyed constantly (roughly 12 o'clock position).
13. Use the turbine controller (13) to adjust the air volume as desired.



Info

Keep in mind that the density of the fog depends on both the set pump capacity and the turbine performance.



Info

If fog emerges from the ventilation grilles of the device, the counter-pressure at the outlet nozzle of the device is too high and the turbine power is set too low! This causes the formation of condensate in the housing interior.

In any case, avoid the formation of condensation so that the device is not damaged by fluid residues.

Operation with flue gas chamber and smoke cartridges



Wear protective gloves

Always wear protective gloves when working with the device, especially when using the flue gas chamber!



Wear a protective mask

When working with the device in closed rooms and when using the flue gas chamber always wear respiratory protection!

Fire simulations as for fire brigade training exercises or the tightness test of certain measurement environments (e. g. ducts) often demand the application of coloured smoke. For these applications please use the TROTEC® flue gas chamber combined with the coloured TROTEC® smoke cartridges.



Info

If the coloured smoke is later to be mixed with the fog generated by the FS 200, the heating must be preheated and ready for operation.

1. Connect the flue gas chamber to the fog transport hose coming from the FS 200.

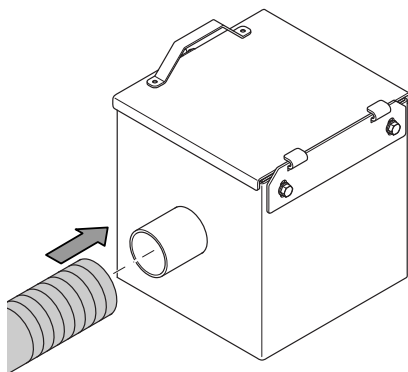

2. If required, connect another hose (Ø 38 mm) to the outlet of the flue gas chamber.
3. Start the turbine of the device at low speed.
4. Open the cover of the flue gas chamber.

5. Put the smoke cartridge into the container.

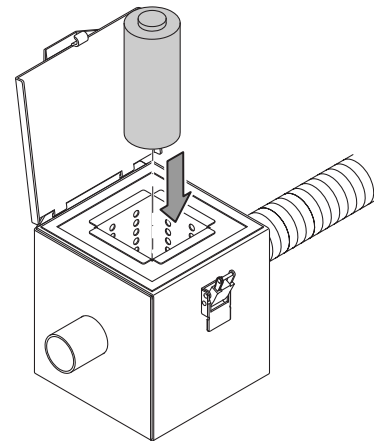

6. Light the smoke cartridge at the very end of the fuse.
7. Then close the cover of the flue gas chamber again as quickly as possible and lock it by use of the tension lock.
8. Set the desired turbine speed.
9. Set the corresponding pump capacity, if fog is to be added to the coloured smoke.

Switching the device off

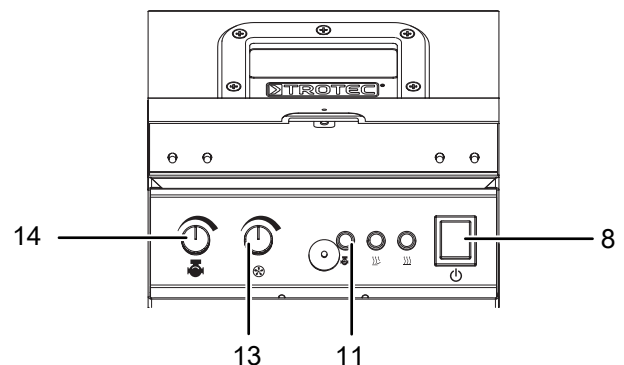

1. Use the controller (14) to switch the pump off again. The *pump* (11) indicator must no longer be illuminated.
2. Set the turbine controller (13) to 12 o'clock position to let the turbine run at medium speed.
3. Let the device run for approx. 20 seconds with these settings to transport remaining fluids from the device.
4. Actuate the on/off switch (8).
⇒ The green lamp goes off.
5. Pull the mains plug.

Available accessories

Designation	Article number
Fog concentrate FluiTect	3.510.010.025

Errors and faults

The device does not start

- Check the power connection.
- Check the power cable and mains plug for damage. If you notice damages, do not try to take the device back into operation.

If the supply cord is damaged, it must be replaced by the manufacturer, its service agent or similarly qualified persons in order to avoid a hazard.

- Check the on-site fusing.

The device does not generate any fog

- Check, whether the device is ready for operation. The *heating ready* indicator (10) must be illuminated in green.
- Check whether the pump controller (14) is set to *8 o'clock* position. The *pump* indicator (11) should be illuminated in blue.
- Check, whether the device is switched on and connected to the mains. The on/off switch (8) should be illuminated in green.
- Check the filling level of the canister. If required, exchange the canister (see "Exchanging the canister").
- Check all hoses and hose connections at the device for tightness.

Your device still does not operate correctly after these checks?

Please contact the Trotec customer service.

Maintenance and repair

Activities required before starting maintenance

- Do not touch the mains plug with wet or damp hands.
- Before any work, remove the mains plug!

Exchanging the canister

A.

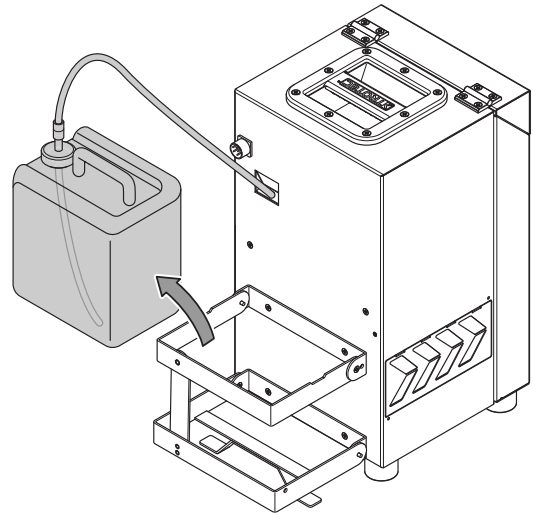

B.

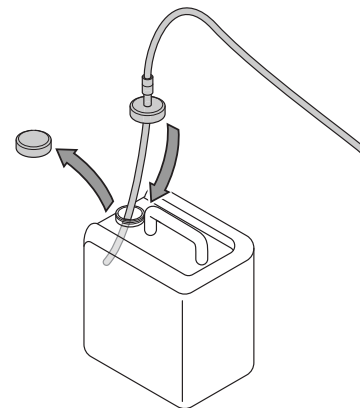

C.

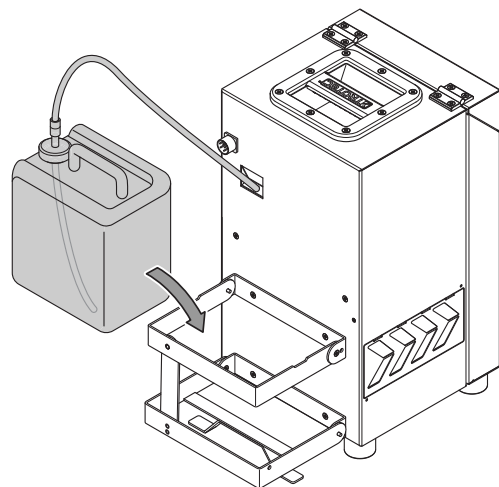

Cleaning filter mats

Both filter mats must be cleaned on a regular basis. In case of excessive contamination or damage the filter mats must be replaced.

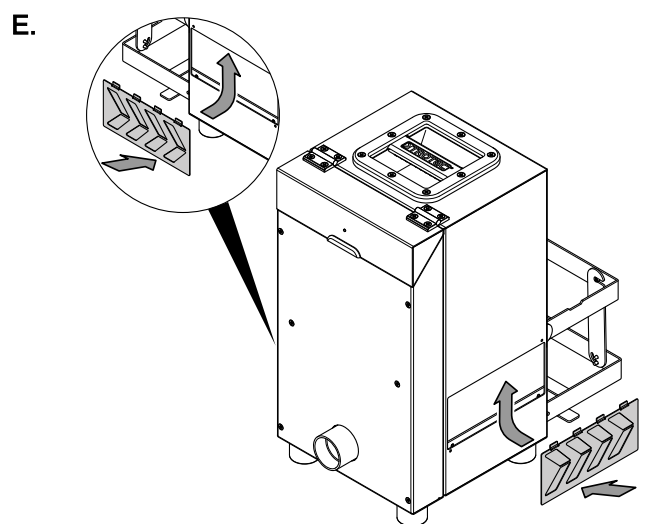
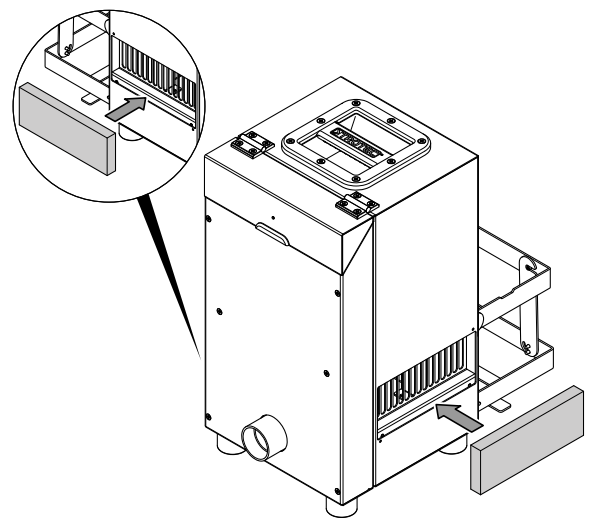
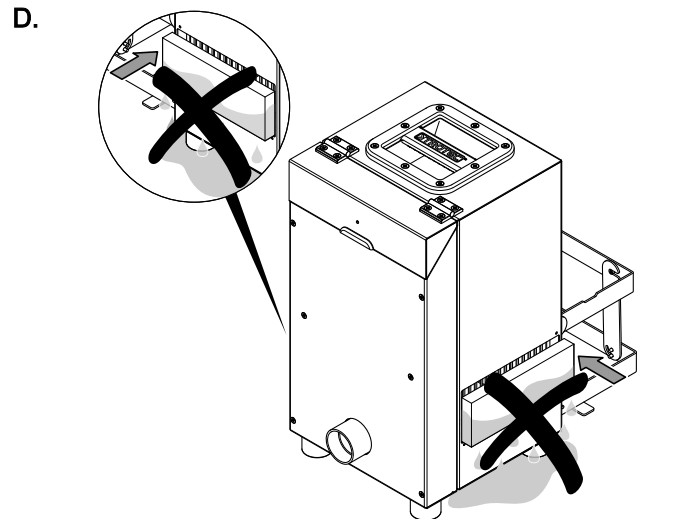
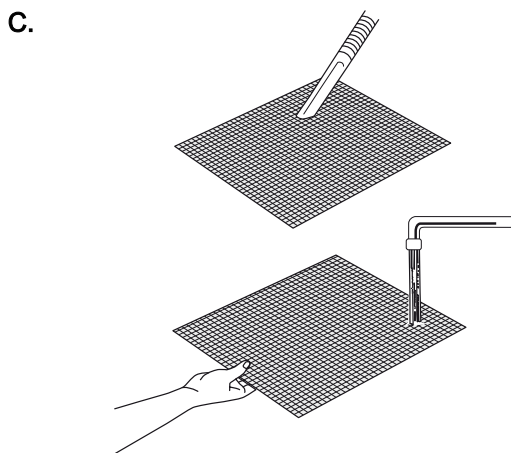
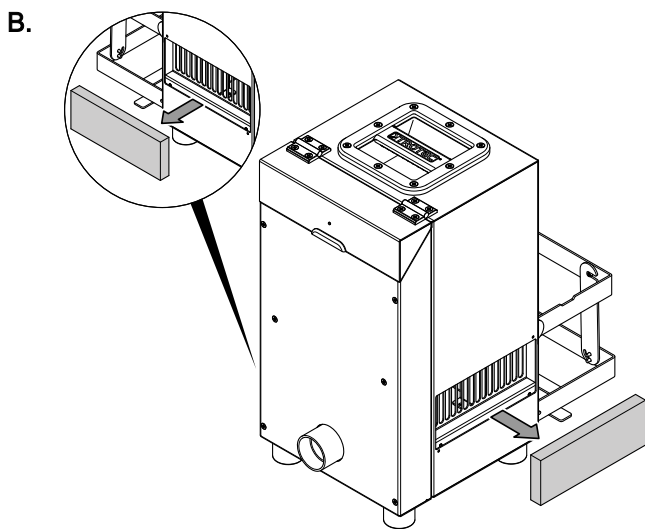
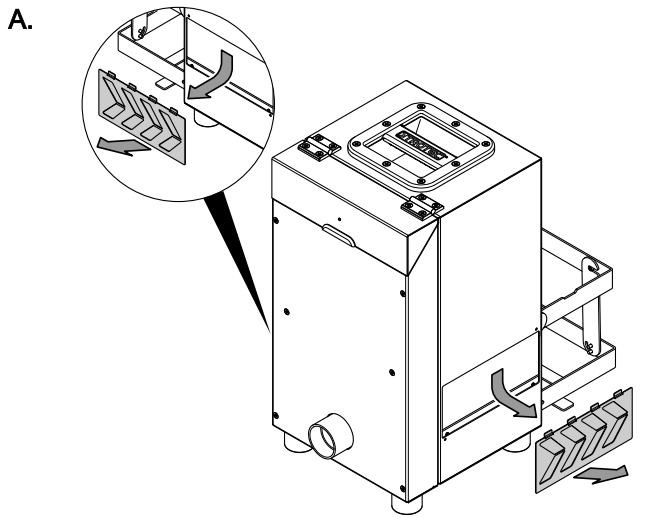

Cleaning the flue gas chamber

Clean the inside of the flue gas chamber (cover and smoke cartridge container) by means of a brass brush.

Do not use a steel brush, for this could lead to the corrosion of the combustion chamber.

Despite the cleaning measures, so-called patina cannot always be prevented. The function of the smoke box is not affected by this.

Cleaning

Clean the device with a soft, damp and lint-free cloth. Make sure that no moisture enters the housing. Do not use any sprays, solvents, alcohol-based cleaning agents or abrasive cleaners, but only clean water to moisten the cloth.

Repair

Do not modify the device or install any spare parts. For repairs or device testing, contact the manufacturer.

Disposal

Always dispose of packing materials in an environmentally friendly manner and in accordance with the applicable local disposal regulations.



The icon with the crossed-out wheeled bin indicates that this device and any associated components must not be disposed of with household waste at the end of their life, in accordance with the Waste Electrical and Electronic Equipment Directive (2012/19/EU) and national laws.

You will find collection points for free return of waste electrical and electronic equipment in your vicinity. The addresses can be obtained from your municipality or local administration. You can also find out about other return options that apply for many EU countries on the website <https://hub.trotec.com/?id=45090>. Otherwise, please contact an official recycling centre for electronic and electrical equipment authorised for your country.

The separate collection of waste electrical and electronic equipment aims to enable the re-use, recycling and other forms of recovery of waste equipment as well as to prevent negative effects for the environment and human health caused by the disposal of hazardous substances potentially contained in the equipment.

Only for United Kingdom

According to Waste Electrical and Electronic Equipment Regulations 2013 (SI 2013/3113) (as amended) devices that are no longer usable must be collected separately and disposed of in an environmentally friendly manner.

EU Declaration of Conformity

ORIGINAL EU Declaration of Conformity for a machine in accordance with 2006/42/EC, Annex II, Part 1, Section A	
1.	Machine: fog and flue gas simulator
2.	Manufacturer: Trotec GmbH Grebbeener Str. 7 52525 Heinsberg Germany online@trotec.com www.trotec.com
3.	./.
4.	This declaration of conformity is issued under the sole responsibility of the manufacturer.
5.	Object of the declaration: FS 200 Year of manufacture: as of 05/2025
6.	The object of the declaration described in point 5 is in conformity with the following Union harmonisation legislation: <ul style="list-style-type: none"> • 2006/42/EC • 2011/65/EU • 2014/30/EU • 2015/863/EU
7.	Applied harmonised standards: <ul style="list-style-type: none"> • EN ISO 12100:2010 (Official Journal C 110 – 08/04/2011) • EN ISO 13857:2019 (Official Journal L 72 – 03/03/2021) • EN 60204-1:2018 (Official Journal L 102 – 02/04/2020) • EN 60335-1:2012, EN 60335-1:2012/AC:2014, EN 60335-1:2012/A11:2014, EN 60335-1:2012/A13:2017, EN 60335-1:2012/A15:2021 (Official Journal L 115 – 13/04/2022) • EN 55011:2016, EN 55011:2016/A1:2017, EN 55011:2016/A11:2020 (Official Journal L 366 – 04/11/2020) • EN 55014-1:2017, EN 55014-1:2017/A11:2020 (Official Journal L 366 – 04/11/2020) • EN 55035:2017, EN 55035:2017/A11:2020 (Official Journal L 089 – 16/03/2021) • EN 61326-1:2013 (Official Journal C 173 – 13/05/2016) • EN 61000-3-2:2014 (Official Journal C 173 – 13/05/2016) • EN IEC 63000:2018 (Official Journal L 155 – 18/05/2020) Common specifications applied: ./. Other applied standards and specifications: ./.
8.	./.
9.	The machine is subject to the conformity assessment procedure on the basis of an internal production control.
10.	Other information: Authorised representative compiling the technical documentation: Trotec GmbH Grebbeener Str. 7 52525 Heinsberg Germany

Heinsberg, 30 April 2025



Joachim Ludwig (Managing Director)

Trotec GmbH

Grebber Str. 7
52525 Heinsberg
Germany

☎ +49 2452 962-0

☎ +49 2452 962-200

✉ online@trotec.com

www.trotec.com