

EN

INSTRUCTIONS
VANE ANEMOMETER



Table of contents

Information on the use of these instructions 2

Safety 2

Information about the device 3

Transport and storage 5

Operation 5

Maintenance and repair 7

Errors and faults 7

Disposal 7

Information on the use of these instructions

Symbols

 **Warning of electrical voltage**
This symbol indicates dangers to the life and health of persons due to electrical voltage.

 **Warning**
This signal word indicates a hazard with an average risk level which, if not avoided, can result in serious injury or death.

 **Caution**
This signal word indicates a hazard with a low risk level which, if not avoided, can result in minor or moderate injury.

Notice
This signal word indicates important information (e.g. material damage), but does not indicate hazards.

 **Info**
Information marked with this symbol helps you to carry out your tasks quickly and safely.

 **Follow the manual**
Information marked with this symbol indicates that the instructions must be observed.

You can download the current version of the instructions and the EU declaration of conformity via the following link:



BA16



<https://hub.trotec.com/?id=40844>

Safety

Read this manual carefully before starting or using the device. Always store the manual in the immediate vicinity of the device or its site of use.

-  **Warning**
Read all safety warnings and all instructions. Failure to follow the warnings and instructions may result in electric shock, fire and/or serious injury.
Save all warnings and instructions for future reference.
- Do not use the device in potentially explosive rooms or areas and do not install it there.
 - Do not use the device in an aggressive atmosphere.
 - Do not immerse the device in water. Do not allow liquids to penetrate into the device.
 - The device may only be used in dry surroundings and must not be used in the rain or at a relative humidity exceeding the operating conditions.
 - Protect the device from permanent direct sunlight.
 - Do not expose the device to strong vibrations.
 - Do not open the device.
 - Do not remove any safety signs, stickers or labels from the device. Keep all safety signs, stickers and labels in legible condition.
 - Use batteries of type 6LR61 (9 V battery).
 - Never charge batteries that cannot be recharged.
 - Different types of batteries and new and used batteries must not be used together.
 - Insert the batteries into the battery compartment according to the correct polarity.
 - Remove discharged batteries. Batteries contain materials hazardous to the environment. Dispose of the batteries according to the national regulations.
 - Remove the batteries from the device if you will not be using the device for a longer period of time.
 - Never short-circuit the supply terminal in the battery compartment!

- Do not swallow batteries! If a battery is swallowed, it can cause severe internal burns within 2 hours! These burns can lead to death!
- If you think batteries might have been swallowed or otherwise entered the body, seek medical attention immediately!
- Keep new and used batteries and an open battery compartment away from children.
- Observe the storage and operating conditions (see Technical data).

Intended use

Only use the device for measurements of air velocity, air temperature and volumetric flow within the measuring range specified in the technical data. Observe and comply with the technical data.

Any use other than the intended use is regarded as misuse.

Reasonably foreseeable misuse

Do not use the device in potentially explosive atmospheres, for measurements in liquids or at live parts.

Any unauthorised changes, modifications or alterations to the device are forbidden.

Personnel qualification

People who use this device must:

- have read and understood the instructions, especially the Safety chapter.

Residual risks



Warning of electrical voltage

There is a risk of a short-circuit due to liquids penetrating the housing!

Do not immerse the device and the accessories in water. Make sure that no water or other liquids can enter the housing.



Warning of electrical voltage

Work on the electrical components must only be carried out by an authorised specialist company!



Warning

Risk of suffocation!

Do not leave the packaging lying around. Children may use it as a dangerous toy.



Warning

The device is not a toy and does not belong in the hands of children.



Warning

Dangers can occur at the device when it is used by untrained people in an unprofessional or improper way! Observe the personnel qualifications!



Caution

Keep a sufficient distance from heat sources.

Notice

To prevent damages to the device, do not expose it to extreme temperatures, extreme humidity or moisture.

Notice

Do not use abrasive cleaners or solvents to clean the device.

Information about the device

Device description

The anemometer BA16 can simultaneously measure the temperature and air velocity, and also calculate the air volume flow.

Temperature measuring is effected by means of an integrated thermistor in °C or °F.

The air velocity can be indicated in the following units:

- m/s
- km/h
- ft/min
- mph
- knots

The air volume flow is displayed as m³/min (CMM).

The sensor is located at a so-called gooseneck probe, which is long and bendable, thus allowing for measurements even in poorly accessible locations.

A HOLD function for holding the current measured value and a MAX/MIN function for displaying the maximum and minimum values of a measurement interval are also available for evaluating the measurements.

The display illumination can be switched on as needed.

When not in use, an automatic switch-off saves the battery.

Device depiction

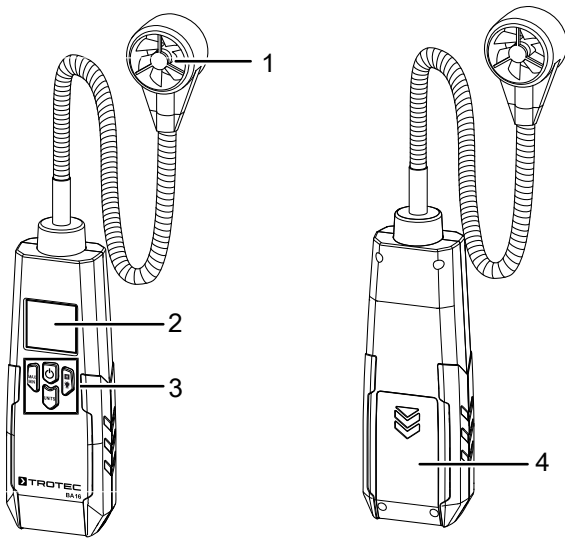

No.	Designation
1	Measuring sensor on gooseneck mount
2	Display
3	Operating elements
4	Battery compartment with cover

Operating elements

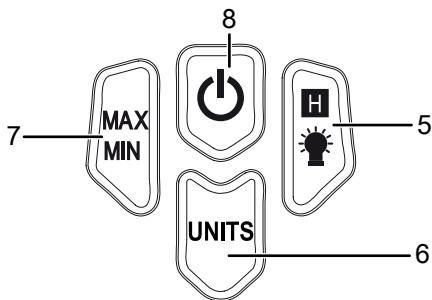

No.	Designation	Function
5	HOLD/lamp button	press briefly: hold measured value
		press and hold: switch background illumination on/off
		press and hold during switch-on: open setting for cross-sectional area
6	UNITS button	press briefly: change unit of air velocity, change to air volume flow display
		press and hold: change temperature unit
		press and hold during switch-on: open setting for automatic switch-off
7	MAX/MIN button	Indication of minimum and maximum values
8	Power button	Switching the device on or off

Display

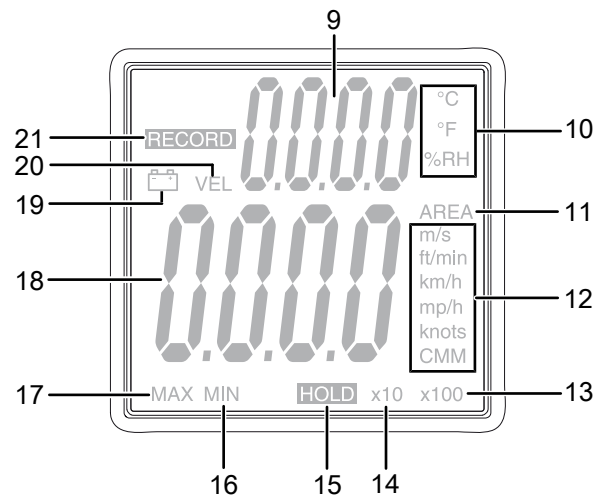

No.	Indication	Meaning
9	Measured temperature value	Measured temperature value indication
10	Temperature unit	Currently selected temperature unit
11	AREA	Volumetric flow profile is displayed or set.
12	Velocity and volumetric flow unit	Currently selected unit of air velocity, indication of volumetric flow unit
13	Measured value x 100	The actual measured value is one hundred times the displayed measured value.
14	Measured value x 10	The actual measured value is ten times the displayed measured value.
15	HOLD	Measured value is being held.
16	Min	Lowest value since the start of the measurement is displayed.
17	Max	Highest value since the start of the measurement is displayed.
18	Measured velocity value	Measured value indication of air velocity or air volume flow
19	Battery status	Lights up when the battery is low.
20	VEL	Air velocity is displayed.
21	RECORD	Measuring interval for MAX/MIN function running.

Technical data

Parameter	Value
Model	BA16
Temperature	
Measuring range	-10 °C to 60 °C (14 °F to 140 °F)
Accuracy	± 1.5 °C (3.0 °F)
Measuring range resolution	0.1 °C (0.1 °F)
Air velocity	
Measuring range	1.00 m/s to 30.00 m/s 196 ft/min to 5900 ft/min 3.6 km/h to 108.0 km/h 2.2 mph to 67.0 mph 1.9 kn to 58.0 kn
Accuracy	± 3 % ± 0.20 m/s ± 3 % ± 40 ft/min ± 3 % ± 0.8 km/h ± 3 % ± 0.4 mph ± 3 % ± 0.4 kn
Measuring range resolution	0.01 m/s 1 ft/min 0.1 km/h 0.1 mph 0.1 kn
General technical data	
Storage temperature	-20 °C to 60 °C (-4 °F to 140 °F) with < 80 % RH (non-condensing)
Operating temperature	0 °C to 50 °C (32 °F to 122 °F) with < 80 % RH (non-condensing)
Power supply	1 x 9 V battery
Device switch-off	after approx. 15 minutes of non-use
Type of protection	IP40
Weight	approx. 263 g (incl. battery)
Dimensions (H x W x D)	162 mm x 54 mm x 32 mm
Length of the gooseneck probe	360 mm

Scope of delivery

- 1 x Device BA16 (without batteries)
- 1 x Transport case
- 1 x Quick guide

Transport and storage

Notice

If you store or transport the device improperly, the device may be damaged.

Note the information regarding transport and storage of the device.

Transport

For transporting the device, use the transport case included in the scope of delivery in order to protect the device from external influences.

Storage

When the device is not being used, observe the following storage conditions:

- dry and protected from frost and heat
- protected from dust and direct sunlight
- stored inside the transport case supplied in order to protect the device from external influences
- at the temperature specified in the technical data
- battery is removed from the device

Operation

Inserting the battery

Notice

Make sure that the surface of the device is dry and the device is switched off.

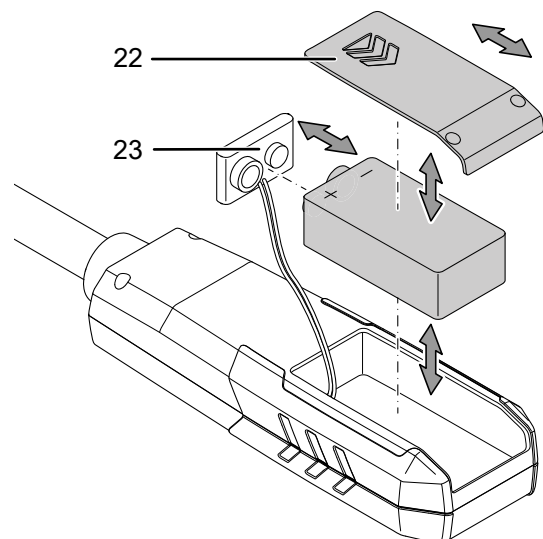

1. Remove the cover (22) from the device.
2. Use the battery clip (23) to connect the new battery with correct polarity.
3. Place the battery with the battery clip (23) back into the battery compartment.
4. Slide the cover (22) back on the device.

Switch-on and measurements

Notice

Note that moving from a cold area to a warm area can lead to condensation forming on the device's circuit board. This physical and unavoidable effect can falsify the measurement. In this case, the display shows either no measured values or they are incorrect. Wait a few minutes until the device has become adjusted to the changed conditions before carrying out a measurement.

1. Press the *Power* button (8) for approx. 3 seconds.
 - ⇒ The display will be switched on and the device ready for operation.
2. Hold the measuring sensor (1) into the area where the measurement is to be performed.
3. Align the vane precisely to the flow direction.
 - ⇒ The measured values for temperature and air velocity are displayed in real time.

Setting the temperature unit

1. Press the *UNITS* button (6) for approx. 3 seconds.
 - ⇒ Depending on the presetting, the *Temperature unit* indication (10) changes to °C or °F and the *Measured temperature value* indication (9) adjusts the measured value accordingly.

Setting the air velocity unit

1. Repeatedly press the *UNITS* button (6) until the desired unit is displayed in the *Velocity and volumetric flow unit* indication (12).

Displaying the air volume flow

1. Repeatedly press the *UNITS* button (6) until the unit for volumetric flow (*CMM*) is displayed in the *Velocity and volumetric flow unit* indication (12).
 - ⇒ The *Measured velocity value* indication (18) changes to displaying the volumetric flow.
 - ⇒ The *AREA* indication (11) is displayed.

Setting the cross-sectional area for volumetric flow measurement

In order to obtain a precise indication of the volumetric flow measurement (*CMM*), the cross-sectional area of the opening to be tested must be entered in m² prior to measuring. For entering the value of the cross-sectional area please proceed as follows:

- ✓ The device is switched off.
1. Simultaneously press and hold the *Power* (8) and *HOLD/lamp* (5) buttons.
 - ⇒ The device is switched on in setting mode.
 - ⇒ The indication *SET AREA* appears on the display.
 - ⇒ Then the setting for the cross-sectional area is opened.
 2. Press the *MAX / MIN* button (7).
 - ⇒ The decimal point will move.

3. Press the *HOLD/lamp* button (5).
 - ⇒ You can alternate between the digits, the selected number flashes.
4. Press the *UNITS* button (6).
 - ⇒ The value of the selected digit changes.
5. Repeat the steps 4. and 5. until the value is set as desired.
6. Switch the device off.
 - ⇒ The set value of the cross-sectional area will be used for the calculation of the volumetric flow after the next switch-on.

Indication of minimum and maximum values

1. Press the *MAX / MIN* button (7).
 - ⇒ The *RECORD* indication (21) appears on the display.
 - ⇒ The measuring interval starts. The value now appearing on the display is the reference value.
 - ⇒ The maximum value is calculated first.
2. Press the *MAX/MIN* button (7) again to switch between maximum and minimum value.
 - ⇒ *MAX* function: The maximum value of the newly started measuring interval is displayed. Values smaller than the one displayed will not be indicated. The *MAX* indication (17) lights up on the display.
 - ⇒ *MIN* function: The minimum value of the newly started measuring interval is displayed. Values exceeding the one displayed will not be indicated. The *MIN* indication (16) lights up on the display.
3. Press the *MAX / MIN* button (7) for approx. 3 seconds to terminate the function.
 - ⇒ The values will be deleted from the buffer memory.

Using the HOLD function

1. Press the *HOLD/lamp* button (5).
 - ⇒ The last measured value will be held on the display.
2. Press the *HOLD/lamp* button (5) again.
 - ⇒ The display again indicates the current measured value.

Switching the display illumination on and off

1. Press the *HOLD/lamp* button (5) for approx. 2 seconds.
 - ⇒ The display illumination goes on.
2. Press the *HOLD/lamp* button (5) again for approx. 2 seconds.
 - ⇒ The display illumination switches off.

Disabling automatic switch-off

As standard, the automatic switch-off function is activated. This results in the device switching off automatically after 15 minutes of non-use. Please proceed as follows to deactivate the automatic switch-off function:

- ✓ The device is switched off.
1. Press and hold the *UNITS* button (6) while switching the device on.
 - ⇒ The indication *disAPO* appears on the display.
 - ⇒ The device is now switched on and ready for use.
 - ⇒ Automatic switch-off is deactivated.



Info

Note that the automatic switch-off function is activated upon the next switch-on. If you do not like to use the function, deactivate the automatic switch-off function as described.

Switching the device off

1. Briefly press the *Power* button (8).
 - ⇒ The device will be switched off.
 - ⇒ The saved measured maximum and minimum values are reset.

Maintenance and repair

Battery change

A battery change is required when the *Battery status* indication (19) lights up or when the device can no longer be switched on (see section Inserting the battery).

Cleaning

Clean the device with a soft, damp and lint-free cloth. Make sure that no moisture enters the housing. Do not use any sprays, solvents, alcohol-based cleaning agents or abrasive cleaners, but only clean water to moisten the cloth.

Repair

Do not modify the device or install any spare parts. For repairs or device testing, contact the manufacturer.

Errors and faults

The device has been checked for proper functioning several times during production. If malfunctions occur nonetheless, check the device according to the following list.

Fault	Cause	Remedy
The device can no longer be switched on.	The battery is dead.	Insert a new battery (see chapter Operation).
The device indicates implausible values of the volumetric flow measurement.	The cross-sectional area of the opening has not been entered (correctly).	Determine and enter the cross-sectional area of the opening (in m ²) (see chapter Operation).

Disposal

Always dispose of packing materials in an environmentally friendly manner and in accordance with the applicable local disposal regulations.



The icon with the crossed-out waste bin on waste electrical or electronic equipment is taken from Directive 2012/19/EU. It states that this device must not be disposed of with the household waste at the end of its life. You will find collection points for free return of waste electrical and electronic equipment in your vicinity. The addresses can be obtained from your municipality or local administration. You can also find out about other return options that apply for many EU countries on the website <https://hub.trotec.com/?id=45090>. Otherwise, please contact an official recycling centre for electronic and electrical equipment authorised for your country.

The separate collection of waste electrical and electronic equipment aims to enable the re-use, recycling and other forms of recovery of waste equipment as well as to prevent negative effects for the environment and human health caused by the disposal of hazardous substances potentially contained in the equipment.



In the European Union, batteries and accumulators must not be treated as domestic waste, but must be disposed of professionally in accordance with Directive 2006/66/EC of the European Parliament and of the Council of 6 September 2006 on batteries and accumulators. Please dispose of batteries and accumulators according to the relevant legal requirements.

Only for United Kingdom

According to Waste Electrical and Electronic Equipment Regulations 2013 (SI 2013/3113) (as amended) and the Waste Batteries and Accumulators Regulations 2009 (SI 2009/890) (as amended), devices that are no longer usable must be collected separately and disposed of in an environmentally friendly manner.

Trotec GmbH

Grebener Str. 7
D-52525 Heinsberg

☎ +49 2452 962-400

☎ +49 2452 962-200

✉ info@trotec.com

www.trotec.com