

EN

ORIGINAL INSTRUCTIONS
LAYER THICKNESS MEASURING
DEVICE



Table of contents

Notes regarding the instructions 2

Safety 2

Information about the device 3

Transport and storage 5

Operation 6

Menu structure 9

MultiMeasure Mobile app 10

PC software 13

Errors and faults 16

Maintenance and repair 16

Disposal 16

Declaration of conformity 17

You can download the current version of the instructions and the EU declaration of conformity via the following link:



BB30



<https://hub.trotec.com/?id=41252>

Safety

Read this manual carefully before starting or using the device. Always store the manual in the immediate vicinity of the device or its site of use.



Warning

Read all safety warnings and all instructions.

Failure to follow the warnings and instructions may result in electric shock, fire and/or serious injury.

Save all warnings and instructions for future reference.

- Do not use the device in potentially explosive rooms or areas and do not install it there.
- Do not use the device in aggressive atmosphere.
- Protect the device from permanent direct sunlight.
- Do not remove any safety signs, stickers or labels from the device. Keep all safety signs, stickers and labels in legible condition.
- Do not open the device.
- Never charge batteries that cannot be recharged.
- Different types of batteries and new and used batteries must not be used together.
- Insert the batteries into the battery compartment according to the correct polarity.
- Remove discharged batteries from the device. Batteries contain materials hazardous to the environment. Dispose of the batteries according to the national regulations.
- Remove the batteries from the device if you will not be using the device for a longer period of time.
- Never short-circuit the supply terminal in the battery compartment!
- Do not swallow batteries! If a battery is swallowed, it can cause severe internal burns within 2 hours! These burns can lead to death!
- If you think batteries might have been swallowed or otherwise entered the body, seek medical attention immediately!

Notes regarding the instructions

Symbols



Warning of electrical voltage

This symbol indicates dangers to the life and health of persons due to electrical voltage.



Warning

This signal word indicates a hazard with an average risk level which, if not avoided, can result in serious injury or death.



Caution

This signal word indicates a hazard with a low risk level which, if not avoided, can result in minor or moderate injury.

Note

This signal word indicates important information (e.g. material damage), but does not indicate hazards.



Info

Information marked with this symbol helps you to carry out your tasks quickly and safely.



Follow the manual

Information marked with this symbol indicates that the instructions must be observed.

- Keep new and used batteries and an open battery compartment away from children.
- Observe the storage and operating conditions (see Technical data).

Intended use

Only use the device for coating thickness measurements. Observe and comply with the technical data.

To use the device for its intended use, only use accessories and spare parts which have been approved by Trotec.

Foreseeable misuse

Do not use the device in potentially explosive atmospheres, for measurements in liquids or at live parts. Trotec accepts no liability for damages resulting from improper use. In such a case, any warranty claims will be voided. Any unauthorised modifications, alterations or structural changes to the device are forbidden.

When using the Bluetooth function, the device emits a low electromagnetic radiation. This is usually harmless. If you intend to use the device near sensitive products such as pacemakers, you should first find out whether or not the low radiation emitted by the device can affect the product's proper functioning.

Personnel qualifications

People who use this device must:

- have read and understood the instructions, especially the Safety chapter.

Residual risks



Warning of electrical voltage

There is a risk of a short-circuit due to liquids penetrating the housing!
Do not immerse the device and the accessories in water. Make sure that no water or other liquids can enter the housing.



Warning of electrical voltage

Work on the electrical components must only be carried out by an authorised specialist company!



Warning

Risk of suffocation!
Do not leave the packaging lying around. Children may use it as a dangerous toy.



Warning

The device is not a toy and does not belong in the hands of children.



Warning

Dangers can occur at the device when it is used by untrained people in an unprofessional or improper way!
Observe the personnel qualifications!



Caution

Keep a sufficient distance from heat sources.

Note

To prevent damages to the device, do not expose it to extreme temperatures, extreme humidity or moisture.

Note

Do not use abrasive cleaners or solvents to clean the device.

Information about the device

Device description

The device BB30 is used to determine the coating thickness on ferromagnetic and non-ferromagnetic metal surfaces. The measuring device functions according to the magnetic induction principle (for coatings on ferromagnetic surfaces) or the eddy-current principle (for coatings on non-ferromagnetic surfaces).

The measuring head can either be connected directly to the device or alternatively via an extension cable.

The scope of delivery includes a set of calibration accessories (FE, NFE, various layer thickness samples) for easy calibration.

The device can be connected to another terminal device via Bluetooth. In combination with the Trotec MultiMeasure Mobile App, there are numerous possibilities for evaluating and displaying the measured values.

The measurement results can be displayed and saved on the terminal device either numerically or in form of a chart. Then, the measurement data can be sent in PDF or Excel format.

The app also includes a report generation function, an organiser function, one for customer management and further analysis options. Moreover, it is possible to share measurements and project data with colleagues in another subsidiary. If MultiMeasure Studio Professional is installed on a PC, you can even use report templates and ready-made text blocks for various fields of application to turn the data into professional reports.

Device depiction

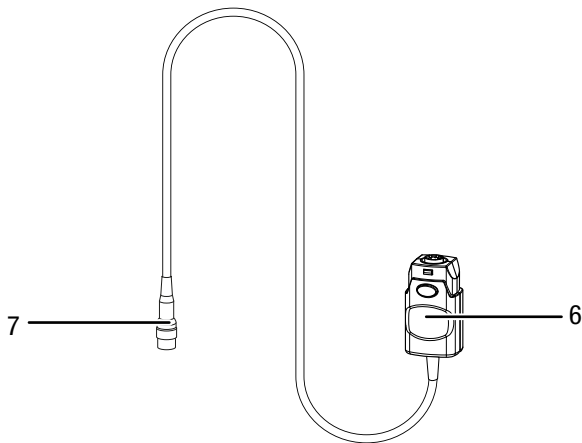
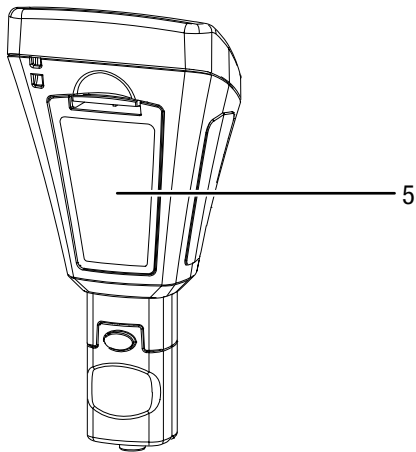
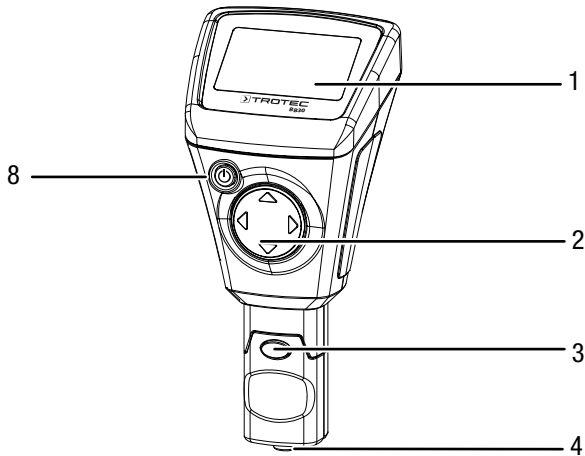

Display

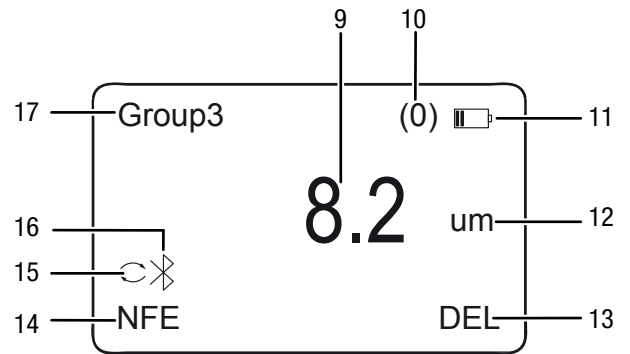

No.	Designation
9	Measurement value indication
10	Indication of the number of measurements
11	Battery indication
12	Unit indication (µm or mils)
13	Delete indication
14	Measuring mode indication
15	Automatic measuring mode indication
16	Bluetooth indication
17	Group indication

No.	Designation
1	Display
2	Cross control with the buttons for up, down, right and left
3	Measuring head (detachable)
4	Sensor
5	Battery compartment with cover
6	Extension cable, device connection
7	Extension cable, measuring head connection
8	Power button

Technical data

Parameter	Value	
Model	BB30	
Sensor	F (ferrous metals)	N (non-ferrous metals)
Possible metallic substrates (examples)	Iron, steel	Copper, aluminium, zinc, bronze and others
Measurement principle	Magnetic induction	Eddy current
Measuring range	0 to 2000 µm 0 to 78.7 mils	0 to 2000 µm 0 to 78.7 mils
Guaranteed tolerance (of the measured value)	0 to 1000 µm (±2 % ±2 µm) 1000 to 2000 µm (±3.5 %) 0 to 39.3 mils (±2 % ±0.08 mils) 39.3 to 78.7 mils (±3.5 %)	0 to 1000 µm (±2 % ±2 µm) 1000 to 2000 µm (±3.5 %) 0 to 39.3 mils (±2 % ±0.08 mils) 39.3 to 78.7 mils (±3.5 %)
Accuracy	0 to 100 µm (0.1 µm) 100 to 1000 µm (1 µm) 1000 to 2000 µm (0.01 mm) 0 to 10 mils (0.01 mils) 10 to 78.7 mils (0.1 mils)	0 to 100 µm (0.1 µm) 100 to 1000 µm (1 µm) 1000 to 2000 µm (0.01 mm) 0 to 10 mils (0.01 mils) 10 to 78.7 mils (0.1 mils)
Minimum bending radius of the object surface	1.5 mm	3 mm
Diameter of the smallest measuring surface	7 mm	5 mm
Min. measurable layer thickness	0.5 µm	0.3 µm
Measurement outside the measuring range (display indication)	- - -	----
Ambient temperature	0 to 40 °C (32 to 104 °F) at 20 to 90 % RH	
Bluetooth standard	Bluetooth 4.0, Low Energy	
Bluetooth frequency range	2.4 GHz	
Bluetooth max. transmission power	10 dBm	
Power supply	2 batteries 1.5 V AAA	

Parameter	Value
Dimensions (length x width x height)	114 x 27 x 54 mm
Weight	152 g

Scope of delivery

- 1 x Layer thickness measuring device BB30
- 1 x Extension cable for sensor
- 2 x 1.5 V batteries AAA
- 1 x Wrist strap
- 1 x Transport case
- 1 x Set with calibration accessories (FE, NFE, various layer thickness samples)
- 1 x Bluetooth Low Energy adapter
- 1 x Quick guide
- 1 x PC software

Transport and storage

Note

If you store or transport the device improperly, the device may be damaged.
Note the information regarding transport and storage of the device.

Transport

For transporting the device, use the transport case included in the scope of delivery in order to protect the device from external influences.

Storage

When the device is not being used, observe the following storage conditions:

- dry and protected from frost and heat
- protected from dust and direct sunlight
- For storing the device, use the transport case included in the scope of delivery in order to protect the device from external influences.
- the storage temperature complies with the values specified in the Technical data
- Batteries are removed from the device

Operation

Inserting the batteries

- Insert the supplied batteries before first use.

Note

Make sure that the surface of the device is dry and the device is switched off.

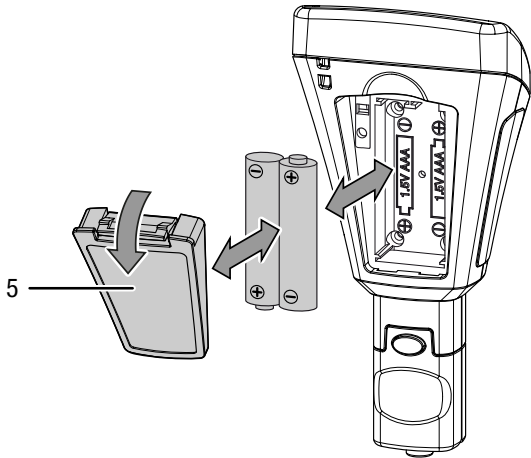

1. Push down the clip at the cover of the battery compartment (5) and remove the cover.
2. If applicable, remove old batteries from the battery compartment.
3. Insert the new batteries in the battery compartment with correct polarity.
4. Put the cover back onto the battery compartment and press the side with the clip down until it clicks into place.

Connecting the extension cable

You can connect the extension cable for the measuring head so as to reach poorly accessible locations.

To do so, please proceed as follows:

1. Disconnect the measuring head (3) from the device by pressing both release buttons and pulling the measuring head off.

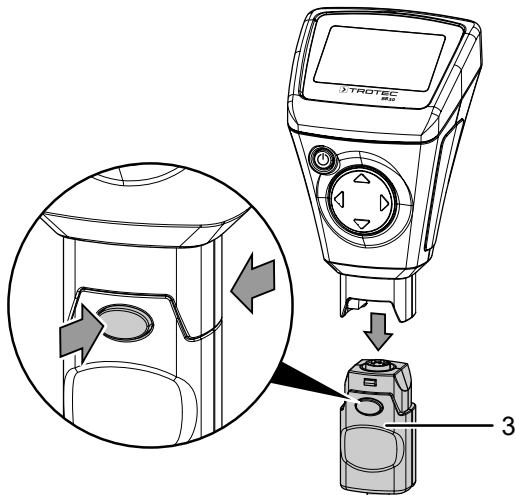

2. Connect the measuring head side of the extension cable (7) to the measuring head (3). Please note that there is only one position that permits the extension cable to be plugged in.

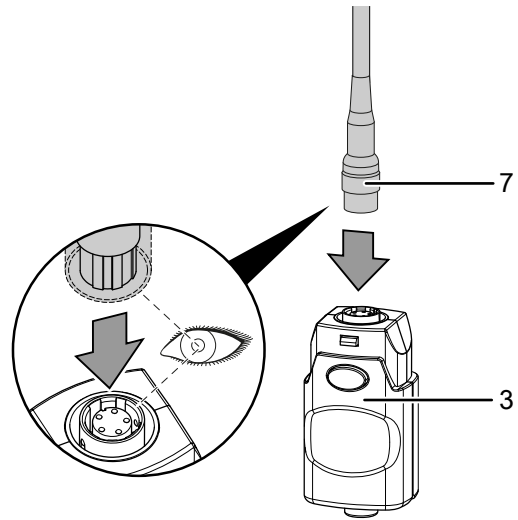

3. Connect the device side of the extension cable (6) to the device by pressing both release buttons and attaching the connector. Please note that the connection can only be established in one way.

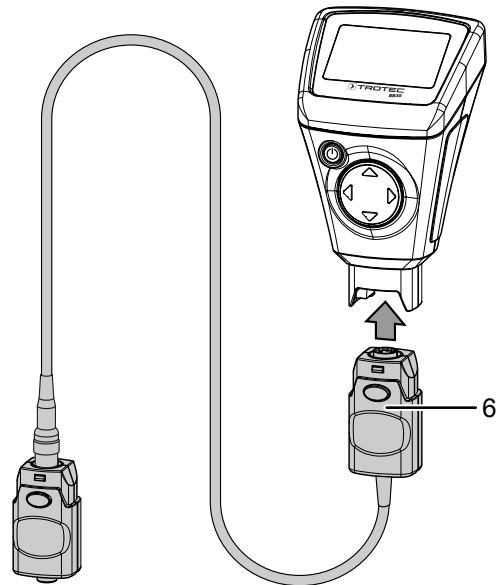

Switching the device on



Info

Note that moving from a cold area to a warm area can lead to condensation forming on the device's circuit board. This physical and unavoidable effect can falsify the measurement. In this case, the display shows either no measured values or they are incorrect. Wait a few minutes until the device has become adjusted to the changed conditions before carrying out a measurement.

1. Press the Power button (8) for approx. 2 seconds.
 ⇨ The display will be switched on and the device ready for operation.

Device calibration

Carry out a zero point calibration before each measuring operation.

You can perform the calibration e.g. at an untreated or uncoated spot of the object to be tested or use the set included in the scope of delivery.



Info

Please bear in mind that the device at hand is a precision measuring device that can determine coating thicknesses of no more than a few micrometres (1 μm is equivalent to one thousandth of a millimetre). The surface condition of most measuring objects is hardly ever perfectly even and homogeneous, even though it might appear differently to the naked eye. Observed under the microscope, even the smoothest surface looks much like a mountain and valley landscape. The tiniest of scratches, cavities or contaminations can therefore already have a negative effect on the expected measurement result, seeing as they will also be a part of the measurement to a greater or lesser extent. It does, however, not affect the accuracy of the device. Even after the calibration unexpected measurement deviations of a few micrometres always have to be regarded in this context.

Hence it is important to handle the supplied calibration accessories with care to avoid scratches and dirt on their respective surface as far as possible.

Zero point calibration

1. Press the Up button (2) for approx. 3 s.
 - ⇒ The following message will be displayed:
Zero Reference
Place Probe
2. Position the sensor (4) on an **uncoated** spot of the material to be measured. The measured medium is to be identical to the **coated** material to be measured thereafter in terms of material composition, shape and surface condition.
 - ⇒ The measurement will be acknowledged with an acoustic signal.
 - ⇒ The measured value will be indicated on the display.
 - ⇒ The following message will be displayed:
Zero Reference
Lift off Probe
 - ⇒ Another acoustic signal will be emitted, then the calibration is completed.

Carrying out a measurement

Carry out a zero point calibration before each measuring operation.

1. If you want to save your measured values, use the Up and Down buttons (2) to select a group (*Group (1)* to *Group (50)*) or else to perform individual measurements select *Group (0)*.
2. Select the desired measuring mode (see Setting the measuring mode).
3. Position the sensor (4) on the material to be measured and perform group measurements or individual measurements.
 - ⇒ The measured value will be indicated on the display (1).
 - ⇒ The measurement will be acknowledged with an acoustic signal.

Adjusting the storage settings for the measured values

- The measured values are stored in *groups*.
- The measured values can be saved in the groups from 1 to 50.
- If you have selected *Group (0)*, individually measured values will only be displayed, but not saved.
- In each group up to 50 measured values can be stored.
- The groups can be selected in the start screen or else via the *Working Mode* submenu.
- The saved measured values can be deleted individually or in groups.

Selecting a group:

1. Select the desired group in the start screen by use of the Up or Down button (2).
2. As alternative, press the Left button (2) to call up the main menu.
3. Use the Up or Down button (2) to select the menu item *Working Mode*.
4. Confirm your selection by pressing the Left button (2).
 - ⇒ A listing of the groups will be displayed.
5. Select the desired group by use of the Up or Down button (2).
6. Confirm your selection by pressing the Left button (2).
 - ⇒ The main menu will be displayed.

Deleting measured values:

1. Press the Left button (2) to call up the main menu.
2. Use the Up or Down button (2) to select the menu item *Measure View*.
3. Confirm your selection by pressing the Left button (2).
 - ⇒ The submenu *Measure View* will be displayed.
4. If you want to delete all measured values, select the menu item *Delete All*, otherwise use the Up or Down button (2) to select a group if you want to delete the measured values of a certain group.

5. Confirm your selection by pressing the Left button (2).
 - ⇒ In case of *Delete All* there will be a prompt, whether you really want to delete all measured values. Confirm the delete operation by pressing the Left button (*OK*) or cancel it by pressing the Right button (*Back*).
 - ⇒ When a group is selected, an overview of the group values will be displayed.
6. Again press the Left button (2) to delete the measured values of the selected group (*Delete Group*) or abort this process by pressing the Right button (*Back*).
 - ⇒ The main menu will be displayed.

Setting the measuring mode

1. Press the Left button (2) to call up the main menu.
2. Use the Up or Down button (2) to select the menu item *Measure Mode*.
3. Confirm your selection by pressing the Left button (2).
 - ⇒ The submenu *Measure Mode* will be displayed. The measuring mode currently activated in the device is marked with a star (e.g. NFE*).
4. Use the Up or Down button (2) to select the desired measuring mode.
5. Confirm your selection by pressing the Left button (2).
 - ⇒ The main menu will be displayed.
 - ⇒ The desired measuring mode is set.
6. Press the Right button (2) to leave the main menu.

Designation	Meaning (sensor F = magnetic induction) (sensor N = eddy current)
<i>AUTO</i>	The sensor selects the measuring mode automatically.
<i>FE</i>	Sensor F is active.
<i>NFE</i>	Sensor N is active.

Setting the unit (µm / mils)

1. Press the Left button (2) to call up the main menu.
2. Use the Up or Down button (2) to select the menu item *Set*.
3. Confirm your selection by pressing the Left button (2).
 - ⇒ The submenu *Set* will be displayed.
4. Use the Up or Down button (2) to select the menu item *Units*.
 - ⇒ The submenu *Units* will be displayed.
5. Use the Up or Down button (2) to select the desired unit.
6. Confirm your selection by pressing the Left button (2).
 - ⇒ The desired unit is set.
 - ⇒ The submenu *Set* will be displayed.

Designation	Meaning
<i>µm</i>	unit: µm (1/1000 mm)
<i>mils</i>	unit: mils (1/1000 inch)

Setting the background illumination

1. Press the Left button (2) to call up the main menu.
2. Use the Up or Down button (2) to select the menu item *Set*.
3. Confirm your selection by pressing the Left button (2).
 - ⇒ The submenu *Set* will be displayed.
4. Use the Up or Down button (2) to select the menu item *Backlight*.
5. Confirm your selection by pressing the Left button (2).
 - ⇒ A scale with the current setting will be displayed.
6. Use the Up or Down button (2) to select the desired setting.
7. Confirm your selection by pressing the Left button (2).
 - ⇒ The desired setting is selected.
 - ⇒ The submenu *Set* will be displayed.

Setting the automatic switch-off

When the automatic switch-off function is activated, the device switches off after approx. 10 minutes without measurement.

1. Press the Left button (2) to call up the main menu.
2. Use the Up or Down button (2) to select the menu item *Set*.
3. Confirm your selection by pressing the Left button (2).
 - ⇒ The submenu *Set* will be displayed.
4. Use the Up or Down button (2) to select the menu item *Auto Power off*.
5. Confirm your selection by pressing the Left button (2).
 - ⇒ The submenu *Auto Power Off* will be displayed.
6. Use the Up or Down button (2) to select the desired setting.
7. Confirm your selection by pressing the Left button (2).
 - ⇒ The desired setting is selected.
 - ⇒ The submenu *Set* will be displayed.

Designation	Meaning
<i>Enable</i>	automatic switch-off enabled
<i>Disable</i>	automatic switch-off disabled

Bluetooth settings

1. Press the Left button (2) to call up the main menu.
2. Use the Up or Down button (2) to select the menu item *Set*.
3. Confirm your selection by pressing the Left button (2).
⇒ The submenu *Set* will be displayed.
4. Use the Up or Down button (2) to select the menu item *Bluetooth*.
5. Confirm your selection by pressing the Left button (2).
⇒ The submenu *Bluetooth* will be displayed.
6. Use the Up or Down button (2) to select the desired setting.
7. Confirm your selection by pressing the Left button (2).
⇒ The desired setting is selected.
⇒ The Bluetooth symbol (16) will be indicated on the display.
⇒ The submenu *Set* will be displayed.
⇒ The device can now be connected to another Bluetooth device (e.g. PC).
⇒ The device will be displayed as BB30.

Designation	Meaning
<i>Enable</i>	Bluetooth enabled
<i>Disable</i>	Bluetooth disabled

Setting the contrast

1. Press the Left button (2) to call up the main menu.
2. Use the Up or Down button (2) to select the menu item *Set*.
3. Confirm your selection by pressing the Left button (2).
⇒ The submenu *Set* will be displayed.
4. Use the Up or Down button (2) to select the menu item *Contrast*.
5. Confirm your selection by pressing the Left button (2).
⇒ The submenu *Contrast* will be displayed.
6. Use the Up or Down button (2) to select the desired setting.
7. Confirm your selection by pressing the Left button (2).
⇒ The desired contrast is set.
⇒ The submenu *Set* will be displayed.

Accessing device information

1. Press the Left button (2) to call up the main menu.
2. Use the Up or Down button (2) to select the menu item *Set*.
3. Confirm your selection by pressing the Left button (2).
⇒ The submenu *Set* will be displayed.
4. Use the Up or Down button (2) to select the menu item *Info*.
5. Confirm your selection by pressing the Left button (2).
⇒ The submenu *Info* will be displayed.
⇒ This submenu contains information on the device name, firmware version and serial number.
6. Press the Left button (2) to return to the submenu *Set*.

Switching the device off

When the automatic switch-off function is activated, the device switches off after approx. 10 minutes without measurement (see Setting the automatic switch-off).

1. Press the Power button (8).
⇒ The device is switched off.

Menu structure

Main menu	Submenu 1	Submenu 2
<i>Working Mode</i>	<i>Group (0) ...</i> <i>Group (50)</i>	-
<i>Measure Mode</i>	<i>Auto</i>	-
	<i>FE</i>	
	<i>NFE</i>	
<i>Set</i>	<i>Unit</i>	<i>um</i>
		<i>mils</i>
	<i>LCD Statistic</i>	<i>None</i>
		<i>Maximum</i>
		<i>Minimum</i>
		<i>Average</i>
		<i>SDev.</i>
	<i>Backlight</i>	<i>Scale</i>
	<i>Auto Power off</i>	<i>Enable</i>
		<i>Disable</i>
	<i>Bluetooth</i>	<i>Enable</i>
<i>Disable</i>		
<i>Contrast</i>	<i>Level 1 to 62</i>	
<i>Info</i>	<i>Product name</i>	
	<i>Firmware</i> <i>Serial number</i>	
<i>Measure View</i>	<i>Delete all</i>	<i>Confirmation prompt for deleting</i>
	<i>Group (1) ...</i> <i>Group (50)</i>	<i>Display of the measured values stored in the respective group.</i>

MultiMeasure Mobile app

MultiMeasure Mobile app



Install the Trotec MultiMeasure Mobile app on the terminal device you want to use in combination with the device.

Info

Some of the app's functions require access to your location and an active Internet connection.

The app is available for download in the Google Play Store as well as in Apple's app store and via the following link:



<https://hub.trotec.com/?id=43083>

Connecting a measuring device



Info

The app can simultaneously be connected to several different measuring devices or measuring devices of the same type and also record several measurements at the same time. The number of sensors that can be connected depends on the terminal device.

Proceed as follows to connect a measuring device to the terminal device:

- ✓ The Trotec MultiMeasure Mobile app is installed.
 - ✓ The Bluetooth function on your terminal device is activated.
1. Switch on the measuring device (see chapter Operation).
 2. Make sure that the Bluetooth function is activated on the measuring device.

3. Start the Trotec MultiMeasure Mobile app on the terminal device.
 - ⇒ A list of active and available sensors will be displayed.
4. Press the  button to refresh the display if the desired measuring device is not displayed as an active measuring device.
 - ⇒ The terminal device now searches all active sensors again and shows them on the display.

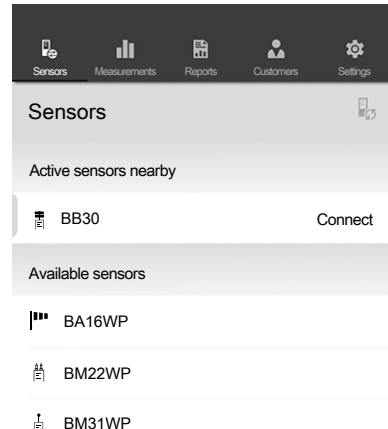

5. Select the desired sensor from the list of active sensors.
 - ⇒ The measuring device and the terminal device establish a connection with each other.
 - ⇒ The measured value indication appears on the display.

Measured value indication

Once the sensor has been successfully connected to the terminal device, the submenu for the measurement opens. Depending on the sensor, the measurement is started immediately, or it is started in the measuring device.

The current measured value and the corresponding unit are displayed in the measured value field.

After several measurements have been carried out, the lowest value, highest value, average value and current value are displayed below the measured value field.

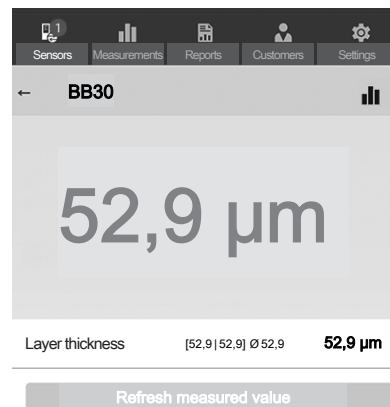

Measuring menu

Press the button to open the measuring menu at the bottom of the display. You can select from the following options in the measuring menu:

- reset the min/max average value
- terminate the connection to the sensor
- view and modify sensor settings
- start recording of measured values

Recording measurements

After pressing the *Start Recording* button, the submenu for selecting the recording mode opens. The following options are available:

- **Individual spot measurement without image:**
A single measured value can be determined and saved.
- **Individual spot measurement with image:**
You can use an existing background image or a new background image to be recorded and display an individual measured value at the correct position in the image.
- **Matrix measurement without background image:**
You can arrange many measuring points in a grid.
- **Matrix measurement with background image:**
You can use an existing background image or a new background image to be recorded and you can superimpose several measured values with the digital background image in colour.

Having selected the recording mode, recording is started and the display returns to the measured value indication. Instead of the button, the symbol of the active sensor flashes to indicate that recording is in progress. You can press this flashing symbol to open the context menu to stop recording.

You can choose from saving or discarding the record after stopping recording.

Menu bar

The functions of the MultiMeasure Mobile App are controlled via the menu bar from which the submenus can be accessed.



Info

Depending on the operating system of the terminal device, the menu bar is located at the top (Android) or bottom (IOS) of the display. In the further description the displays of the Android system are shown as an example.

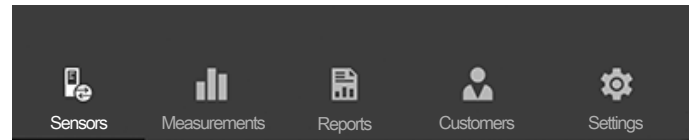

Designation	Function
Sensors	Opens the sensors overview. After connecting to the selected sensor, the submenu for the measurement opens.
Measurements	Opens the overview of saved measurements. The measurement series can be opened and edited.
Reports	Opens the overview of saved reports. You can generate on-site reports for the measurements and link them to customer data.
Customers	Opens the customers overview. You can select existing customers or create new customers.
Settings	Opens the settings menu. You can select the language and – depending on the measuring device – adjust different settings.

Submenu measurements

In the submenu *MEASUREMENTS*, the saved recordings of the measured values are displayed along with date, name and number of measuring points. Having selected the desired recording, the context menu of the measurement opens. Depending on the sensor type and the measuring mode, different functionalities can be opened. The following menu items are available:

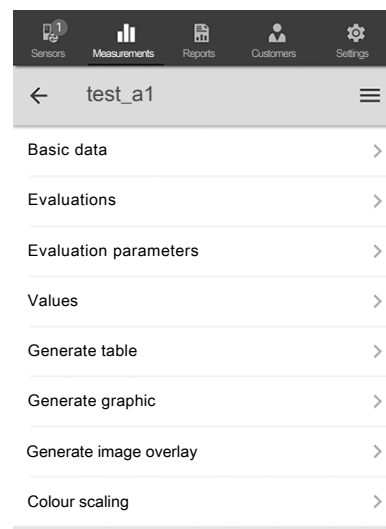

- **Basic data:**
Opens an overview of the data saved for the measurement.
- **Evaluations:**
Opens an overview of the evaluations generated for the measurement (photos, graphics and tables).

- **Evaluation parameters:**
Opens a menu to select and deselect individual evaluation parameters.
- **Values:**
Opens a tabular overview of all logged values for the measurement.
- **Generate table:**
Creates a table containing the logged values of the measurement and saves it as a *.CSV file.
- **Generate graphic:**
Creates a graphic representation of the logged values and saves it as a *.PNG file.
- **Generate image overlay:**
Combines a background image with the representation of the measured values.
- **Colour scaling:**
Allows you to adjust the colour display of the measured values.

Submenu reports

The reports generated in the MultiMeasure Mobile app are short reports providing a fast and simple documentation.

You can select from the following options in the *REPORTS* submenu:

- **Indicate existing reports:**
Having selected a report, a submenu opens where you can view and modify information.

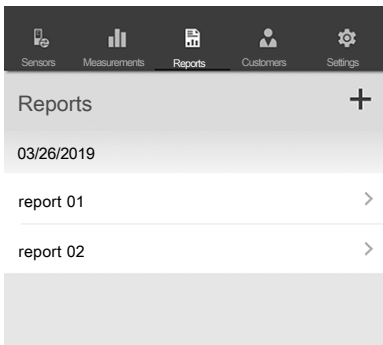

- **Generate a new report:**
Press the + button to open the input mask for a new report.

Submenu customers

Using the integrated customer management function all of the measured data can be assigned to specific clients via the app.

You can select from the following options in the *CUSTOMERS* submenu:

- **Call up an already created customer:**
Having selected a report, a submenu opens where you can view and modify information or directly start a measurement.

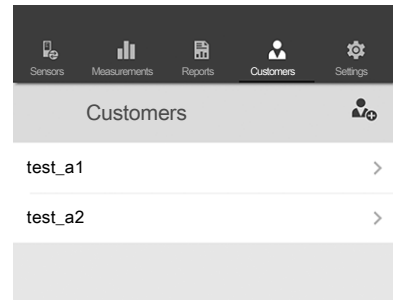

- **Creating a new customer:**
Press the + button to open the input mask for a new customer. You can create a new customer set or import an existing contact from the phone book of the terminal device.

Submenu settings

In the submenu *SETTINGS* you can adjust different settings, e.g. changing the menu language.



Note

The various sensors have slightly different setting options.

Example: Submenu *SETTINGS*:

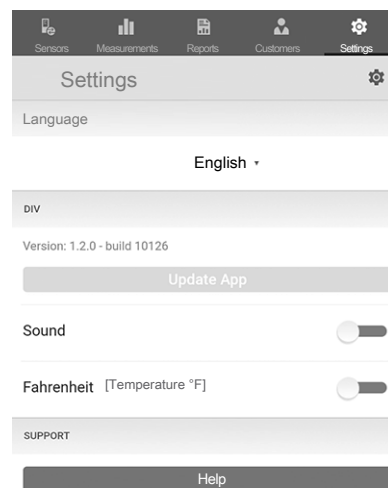

PC software

Using the software *Coating Thickness Tester* stored measurement data can be called up and saved via a Bluetooth interface.

The software is available for download at www.trotec.de.



Info

The supplied free software is designed for useful basic functionalities. Trotec assumes no liability with regard to this free software and also provides no support on that score. Trotec accepts no liability concerning the use of this free software and is under no obligation to make adjustments or to further develop updates or upgrades.

Installation requirements

Ensure that the following minimum requirements for installing the PC software are fulfilled:

- Supported operating systems:
 - Windows 7
 - Windows 8
 - Windows 8.1
 - Windows 10
- Hardware requirements:
 - Standard USB interface
 - Min. 7 MB of free hard disk space
 - Recommended resolution: 1280*1024 with 16 bit
 - .NET Framework 2.0 or higher

Installing the PC software

1. Insert the data medium with the software into the drive or download the current software from the *Service* area of Trotec download centre.
2. Double-click the installation file *Setup.exe*.
3. Follow the instructions of the installation wizard.



Info

Even if your PC leaves the factory already equipped with an integrated Bluetooth interface, this interface is not suited to establish a connection to the measuring device. This can **only** be accomplished by use of the supplied BLE adapter.



Info

Windows 10: If your PC comes equipped with an integrated Bluetooth interface, it needs to be disabled in Windows 10, otherwise there will be connection issues between measuring device and the supplied BLE adapter.

Starting the PC software

1. Enable the Bluetooth function of the measuring device.
2. Connect the supplied BLE adapter to your computer using a free USB port.
3. Start the PC software.

4. Click on the *Discovery* button (23).
 - ⇒ The software starts the search for the device.
 - ⇒ Once the software has found the device, the device name is displayed in the corresponding column *Device Name* (28).
5. Select the device name and click on the *Connect* button (27).
 - ⇒ The software connects to the device.
 - ⇒ A Bluetooth icon (29) appears in the Real time connection display (20) if the connection was established successfully.
 - ⇒ You can now download data from the device or with each measurement directly load values to the software in real time and later save the entire dataset on your PC (see Saving measured values (export)). With the so-called live measurement the number of measured values per group is not limited to 50.

Retrieving measured values (download)

By use of the software you can download the measured values from the device. You can choose which groups to download.

If you perform a measurement within the PC's reception range, the stored measured values will directly be transferred to the software.

- ✓ The device has been connected to the software as described in Starting the PC software.
1. Select the groups you want to download by choosing the group numbers (from ... to ...) from the two drop-down menus under (18). As with the device the value range here too is 1 to 50.
 2. Click on the *Read* button (19).
 - ⇒ Data is being loaded.
 3. A progress bar appears beside the drop-down box *Data filtering* (22). The loading process is completed, when the bar is filled. If the loading process cannot be completed successfully, an error message will be displayed instead. In that event check the Bluetooth connection between device and PC. If in doubt, disconnect and then re-establish the connection. Proceed as described in Starting the PC software and then try to load the desired data again.
 4. Select a group from the drop-down box *Data filtering* (22) to display the measured values.
 - ⇒ The measured values are displayed in the table below the drop-down box *Data filtering* (22).
 - ⇒ When clicking on a measured value in the table, further information will be indicated under *Statistics* (21).

Saving measured values (export)

You can export a selected group as Excel file and save it on your PC. There the table looks as it does in the software.

1. Select the *File* menu tab (25).
2. Select the submenu *Save as*.
3. Select the storage location and insert the desired file name.
4. Then click on *Save*.
 - ⇒ The measured values from the selected group are stored in the Excel table.

PC software overview

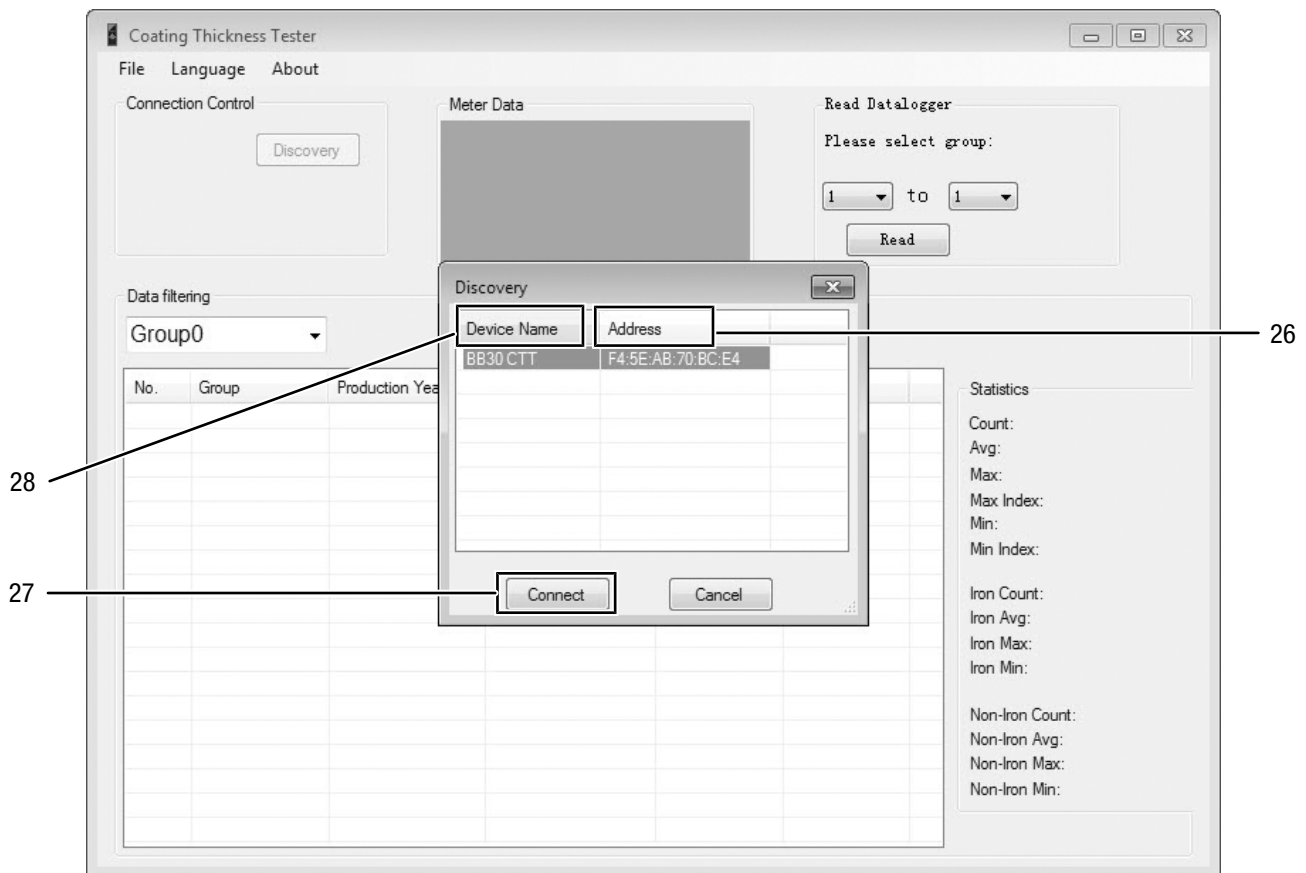
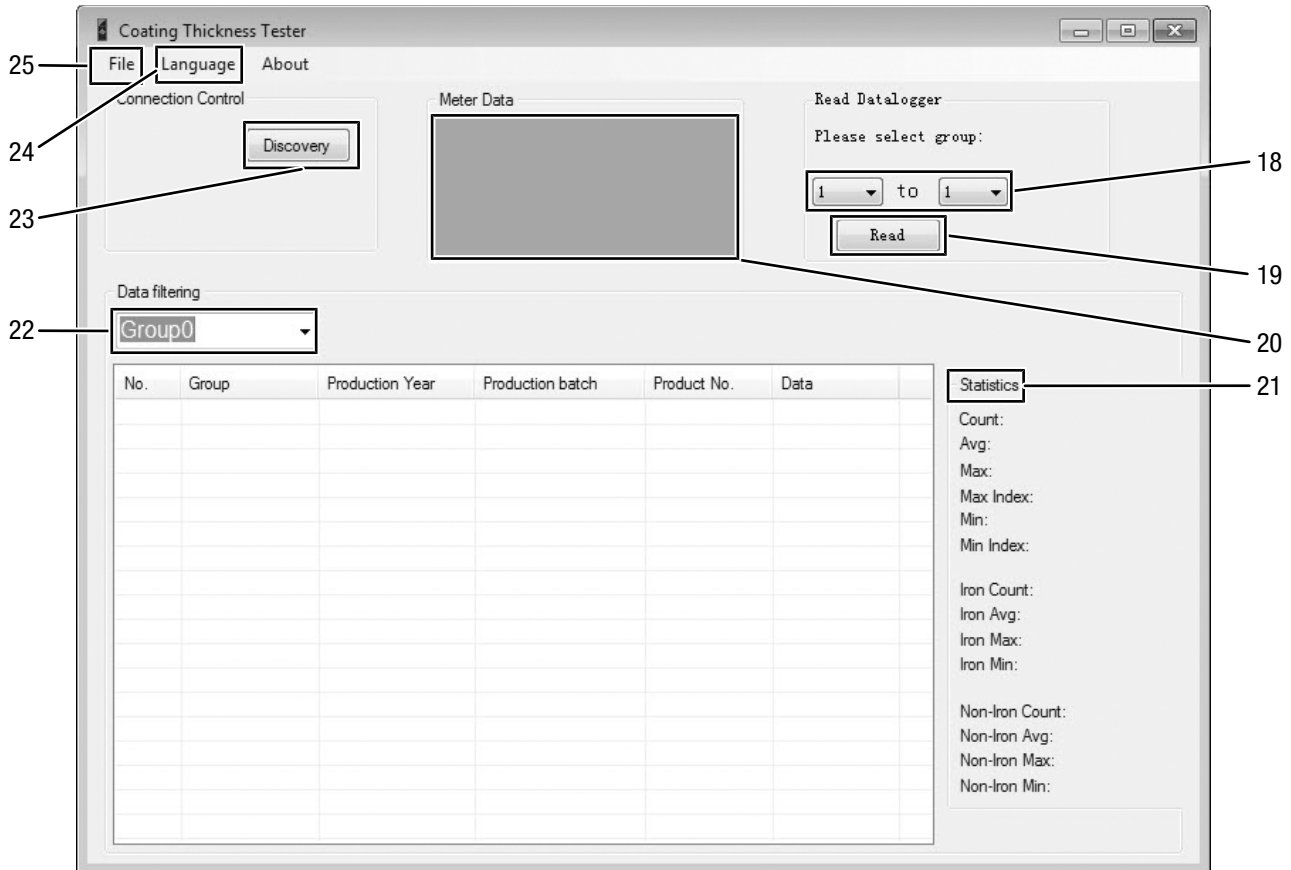

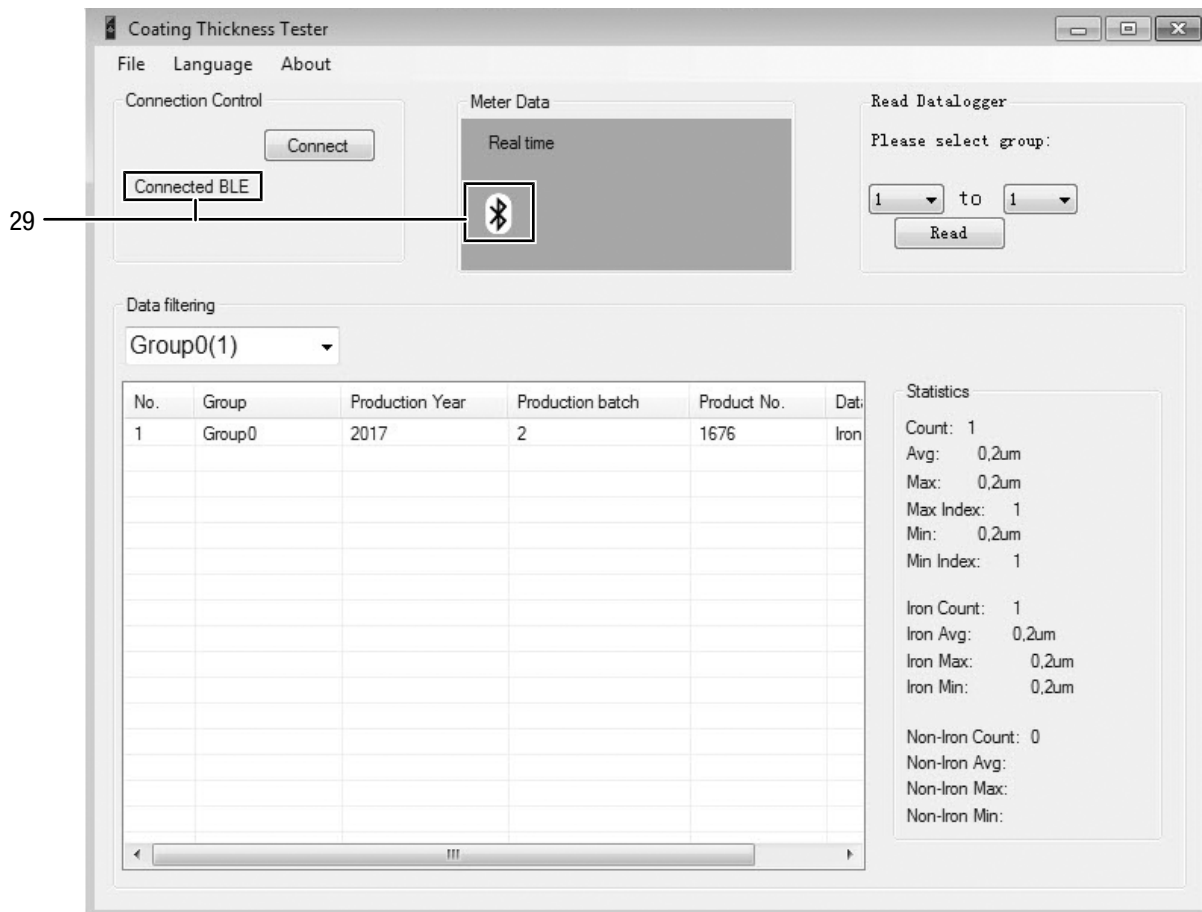

No.	Designation	Meaning
18	Group selection	Selecting groups for reading
19	<i>Read</i> button	Reading the selected groups
20	Real time connection display	Indicating the real-time connection status
21	Indication of the statistics	Further information on the selected measurement series
22	<i>Data filtering</i> selection	Selecting a group for displaying measurement data
23	<i>Discovery</i> button	Starting the search for the device
24	File menu	Saving and loading data sets
25	Language menu	Selecting the menu language
26	Display of the MAC address	Indicating the MAC address of the device
27	<i>Connect</i> button	Establishing a connection to the selected device
28	Indication of the device name	Indicating the name of the device
29	Bluetooth icon	Indicating an established real-time connection to the device

Errors and faults

The device has been checked for proper functioning several times during production. If malfunctions occur nonetheless, check the device according to the following list.

The device does not switch on:

- Check the charging status of the batteries. Change the batteries, if required.
- Check that the batteries are properly positioned. Check the polarity is correct.
- Never carry out an electrical check yourself; instead, contact your Trotec customer service.

Table of faults

The following error codes can be displayed:

Error code	Cause of error
Err1	Measuring mode FE: Layer thickness outside the measuring range
Err2	Measuring mode NFE: Layer thickness outside the measuring range
Err3	Measuring mode AUTO: Layer thickness outside the measuring range
Err4	Measuring mode FE: No FE data could be detected.
Err5	Measuring mode NFE: No NFE data could be detected.

Maintenance and repair

Battery change

A battery change is required, when the Battery indication (11) lights up or the device can no longer be switched on. See chapter Operation.

Cleaning

Clean the device with a soft, damp and lint-free cloth. Make sure that no moisture enters the housing. Do not use any sprays, solvents, alcohol-based cleaning agents or abrasive cleaners, but only clean water to moisten the cloth.

Repair

Do not modify the device or install any spare parts. For repairs or device testing, contact the manufacturer.

Disposal

Always dispose of packing materials in an environmentally friendly manner and in accordance with the applicable local disposal regulations.



The icon with the crossed-out waste bin on waste electrical or electronic equipment is taken from Directive 2012/19/EU. It states that this device must not be disposed of with the household waste at the end of its life. You will find collection points for free return of waste electrical and electronic equipment in your vicinity. The addresses can be obtained from your municipality or local administration. You can also find out about other return options that apply for many EU countries on the website <https://hub.trotec.com/?id=45090>. Otherwise, please contact an official recycling centre for electronic and electrical equipment authorised for your country.

The separate collection of waste electrical and electronic equipment aims to enable the re-use, recycling and other forms of recovery of waste equipment as well as to prevent negative effects for the environment and human health caused by the disposal of hazardous substances potentially contained in the equipment.



In the European Union, batteries and accumulators must not be treated as domestic waste, but must be disposed of professionally in accordance with Directive 2006/66/EC of the European Parliament and of the Council of 6 September 2006 on batteries and accumulators. Please dispose of batteries and accumulators according to the relevant legal requirements.

Only for United Kingdom

According to Waste Electrical and Electronic Equipment Regulations 2013 (SI 2013/3113) (as amended) and the Waste Batteries and Accumulators Regulations 2009 (SI 2009/890) (as amended), devices that are no longer usable must be collected separately and disposed of in an environmentally friendly manner.

Declaration of conformity

We – Trotec GmbH – declare in sole responsibility that the product designated below was developed, constructed and produced in compliance with the requirements of the EU Radio Equipment Directive in the version 2014/53/EU.

Product model / Product: BB30

Product type: layer thickness measuring device

Year of manufacture as of: 2018

Relevant EU directives:

- 2014/30/EU

Applied harmonised standards:

- EN 300 328 V2.2.2
- EN 61326-2-1:2013

Applied national standards and technical specifications:

- EN 301 489-1 Draft Version 2.2.0:2017-03
- EN 301 489-17 Draft Version 3.2.0:2017-03
- EN 61326-1:2013
- EN 61326-2-2:2013
- EN 62479:2010
- IEC 61326-1:2012
- IEC 61326-2-1:2012
- RF-PHY.TS.5.0.3
- TCRL 2018-2

Manufacturer and name of the authorised representative of the technical documentation:

Trotec GmbH

Grebener Straße 7, D-52525 Heinsberg

Phone: +49 2452 962-400

E-mail: info@trotec.de

Place and date of issue:

Heinsberg, 17.02.2023



Joachim Ludwig, Managing Director

Trotec GmbH

Grebener Str. 7
D-52525 Heinsberg

☎ +49 2452 962-400

☎ +49 2452 962-200

✉ info@trotec.com

www.trotec.com