

BP25



EN

INSTRUCTIONS
DEW POINT SCANNER

 **TROTEC**

Table of contents

Information on the use of these instructions 2

Safety 2

Information about the device 4

Transport and storage 6

Operation 6

Maintenance and repair 8

Errors and faults 8

Disposal 8

Information on the use of these instructions

Symbols

 **Warning of electrical voltage**
This symbol indicates dangers to the life and health of persons due to electrical voltage.

 **Warning of laser radiation**
This symbol indicates dangers to the health of persons due to laser radiation.

 **Warning**
This signal word indicates a hazard with an average risk level which, if not avoided, can result in serious injury or death.

 **Caution**
This signal word indicates a hazard with a low risk level which, if not avoided, can result in minor or moderate injury.

Notice
This signal word indicates important information (e.g. material damage), but does not indicate hazards.

 **Info**
Information marked with this symbol helps you to carry out your tasks quickly and safely.

 **Follow the manual**
Information marked with this symbol indicates that the instructions must be observed.

You can download the current version of the instructions and the EU declaration of conformity via the following link:



BP25



<https://hub.trotec.com/?id=42638>

Safety

Read this manual carefully before starting or using the device. Always store the manual in the immediate vicinity of the device or its site of use.

-  **Warning**
Read all safety warnings and all instructions. Failure to follow the warnings and instructions may result in electric shock, fire and/or serious injury.
Save all warnings and instructions for future reference.
- Do not use the device in potentially explosive rooms or areas and do not install it there.
 - Do not use the device in an aggressive atmosphere.
 - Do not immerse the device in water. Do not allow liquids to penetrate into the device.
 - Protect the device from permanent direct sunlight.
 - Do not open the device.
 - Do not remove any safety signs, stickers or labels from the device. Keep all safety signs, stickers and labels in legible condition.
 - Avoid looking directly into the laser beam.
 - Never point the laser beam at people or animals.
 - Use batteries of type 6LR61 (9 V battery).
 - Never charge batteries that cannot be recharged.
 - Different types of batteries and new and used batteries must not be used together.
 - Insert the batteries into the battery compartment according to the correct polarity.
 - Remove discharged batteries. Batteries contain materials hazardous to the environment. Dispose of the batteries according to the national regulations.
 - Remove the batteries from the device if you will not be using the device for a longer period of time.
 - Never short-circuit the supply terminal in the battery compartment!

- Do not swallow batteries! If a battery is swallowed, it can cause severe internal burns within 2 hours! These burns can lead to death!
- If you think batteries might have been swallowed or otherwise entered the body, seek medical attention immediately!
- Keep new and used batteries and an open battery compartment away from children.
- Observe the operating conditions specified in the Technical data chapter.

Intended use

Only use the device for temperature measurements by means of an infrared sensor within the measuring range specified in the technical data. Observe and comply with the technical data.

Any use other than the intended use is regarded as misuse.

Reasonably foreseeable misuse

The device must not be pointed at people. Do not use the device in potentially explosive atmospheres, for measurements in liquids or at live parts. Any unauthorised modifications, alterations or structural changes to the device are forbidden.

Personnel qualification

People who use this device must:



- be aware of the dangers that occur when working with laser measuring devices.
- have read and understood the instructions, especially the Safety chapter.

Safety signs and labels on the device

Notice

Do not remove any safety signs, stickers or labels from the device. Keep all safety signs, stickers and labels in legible condition.

The following safety signs and labels are attached to the device:

Warning sign	 Laser 2 
Meaning	The warning sign indicates that the device is equipped with a class 2 laser. Do not look directly into the laser beam or the opening from which the laser beam emerges!

Residual risks



Warning of electrical voltage

There is a risk of a short-circuit due to liquids penetrating the housing!

Do not immerse the device and the accessories in water. Make sure that no water or other liquids can enter the housing.



Warning of electrical voltage

Work on the electrical components must only be carried out by an authorised specialist company!



Warning of laser radiation

Laser class 2, P max.: < 1 mW, λ: 400-700 nm, EN 60825-1:2014

Do not look directly into the laser beam or the opening from which it emerges.

Never point the laser beam at people, animals or reflective surfaces. Even brief eye contact can lead to eye damage.

Examining the laser output aperture by use of optical instruments (e.g. magnifying glass, magnifiers and the like) entails the risk of eye damage.

When working with a laser of class 2, observe the national regulations on wearing eye protection.



Warning

Risk of suffocation!

Do not leave the packaging lying around. Children may use it as a dangerous toy.



Warning

The device is not a toy and does not belong in the hands of children.



Warning

Dangers can occur at the device when it is used by untrained people in an unprofessional or improper way! Observe the personnel qualifications!



Caution

Keep a sufficient distance from heat sources.

Notice

To prevent damages to the device, do not expose it to extreme temperatures, extreme humidity or moisture.

Notice

Do not use abrasive cleaners or solvents to clean the device.

Information about the device

Device description

The dew point scanner BP25 uses an infrared and humidity sensor to measure surface temperatures as well as air temperature and humidity without contact. An integrated dual laser serves for the determination of the measuring spot diameter.

The dew point is detected from these values. If the temperature in one part of the room is at or below the dew point, then the humidity in the air condenses. This can cause mould to form. Using the dew point scanner BP25 to measure the dew point, you can accurately pinpoint areas at risk of mould formation or poor insulation.

The risk of condensation forming at the measuring spot is indicated both by an acoustic alarm function and a changed display colour.

When not in use, an automatic switch-off saves the battery.

Measuring principle

The device measures the temperature by means of an infrared sensor. Important factors playing a role in the temperature measurement are the measuring spot diameter and the emissivity of the surface to be measured, which is set to the fixed value of 0.95 here.

Measuring spot

Observe the ratio of the distance to the measuring spot diameter. The larger the distance to the object, the larger the measuring spot diameter and hence, the less precise the measured result. The on-demand dual laser indicates the approximate diameter of the measuring spot, which is used by the device to calculate an average temperature. Consequently, it is a mere aiming aid and not intended for the actual temperature measurement. The smaller the measuring spot, the more precise is the measured result.

Device depiction

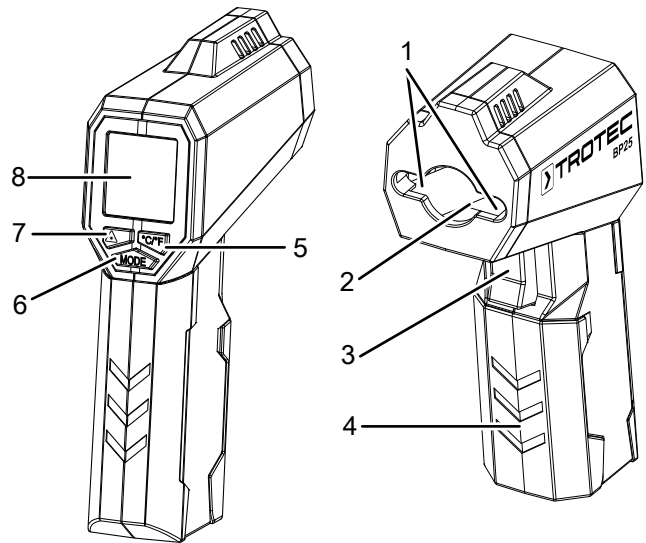

No.	Designation
1	Laser
2	Infrared sensor
3	Measurement button
4	Battery compartment with cover
5	Temperature unit button
6	Mode button
7	Laser button
8	Display

DUAL-LASER

Distance : Spot = 20 : 1

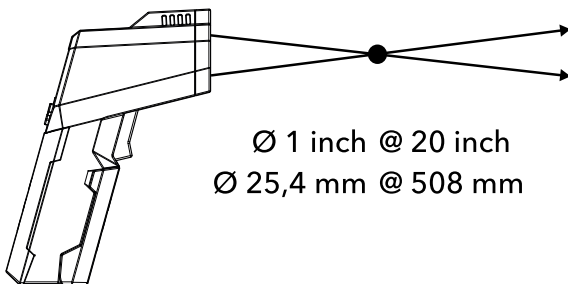

Display

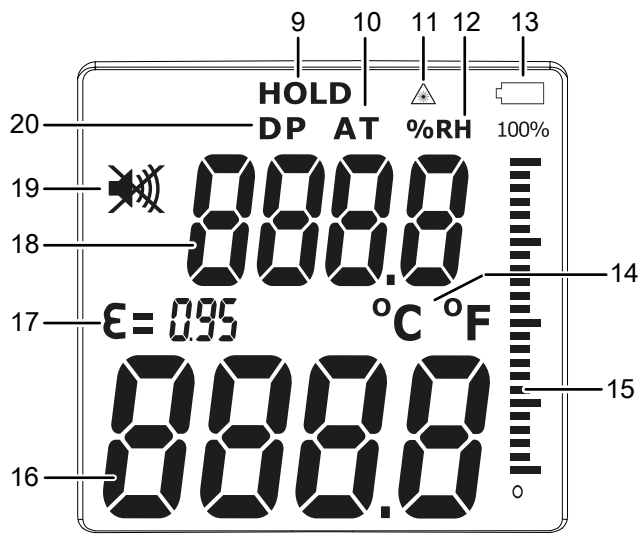

No.	Designation	Function
9	<i>HOLD</i> indication	HOLD function active
10	<i>AT</i> indication	Measurement value display 2 (18) indicates ambient temperature
11	<i>Laser</i> indication	Laser is switched on
12	<i>%RH</i> indication	Measurement value display 2 (18) indicates relative humidity
13	<i>Battery</i> indication	Battery status, flashes when the battery is empty
14	<i>Temperature unit</i> indication	Indicates the current temperature unit: °C °F
15	Scale	Indicates the risk of condensation forming at the measuring spot 0 – 100 %
16	Measurement value display 1	Indicates the temperature at the measuring spot
17	<i>Emissivity</i> indication	Indicates the preset emissivity
18	Measurement value display 2	Indicates dew point temperature, ambient temperature or relative humidity
19	<i>Alarm sound</i> indication	Alarm sound: = alarm sound active = alarm sound inactive
20	<i>DP</i> indication	Measurement value display 2 (18) indicates dew point

Technical data

Parameter	Value
Model	BP25
Weight	163 g
Dimensions (length x width x height)	82 mm x 58 mm x 168 mm
Temperature measuring range	-50°C to 260°C (-58°F to 500°F)
Basic accuracy Temperature	-50 to 20 °C (-58 to 68 °F) ±3.5 °C 20 to 260 °C (68 to 500 °F) 1 % ±1.5 °C
Measuring range for relative humidity	0 to 100 % RH
Basic accuracy Relative humidity	±3.5 % (20 to 80 %)
Measuring range Dew point temperature	-30 to 100 °C (-22 to 212 °F)
Basic accuracy Dew point temperature	-30 to 100 °C (-22 to 212 °F) ±2.0 %
Resolution	0.1 °C / °F
Target display	Laser class II, 630 to 670 nm < 1 mW
Emissivity	0.95
Optical resolution	20:1 (D:S)
Smallest measuring spot	∅ 25.4 mm (distance 508 mm)
Spectral sensitivity	8 to 14 µm
Response time	< 150 ms
Operating temperature	0 °C to 50 °C (32 °F to 122 °F), 10 % to 90 % RH
Storage conditions	-10 °C to 60 °C, < 80 % RH
Power supply	9 V battery
Switch-off	After approx. 15 minutes of non-use in SCAN mode. After approx. 1 minute of non-use in HOLD mode.

Scope of delivery

- 1 x Dew point scanner BP25 (without battery)
- 1 x Device bag
- 1 x Manual

Transport and storage

Notice

If you store or transport the device improperly, the device may be damaged.
 Note the information regarding transport and storage of the device.

Transport

For transporting the device, use the bag included in the scope of delivery in order to protect the device from external influences.

Storage

When the device is not being used, observe the following storage conditions:

- dry and protected from frost and heat
- protected from dust and direct sunlight
- protected from dust ingress in the supplied bag
- at the temperature specified in the technical data
- Batteries are removed from the device

Operation

Inserting the battery

Notice

Make sure that the surface of the device is dry and the device is switched off.

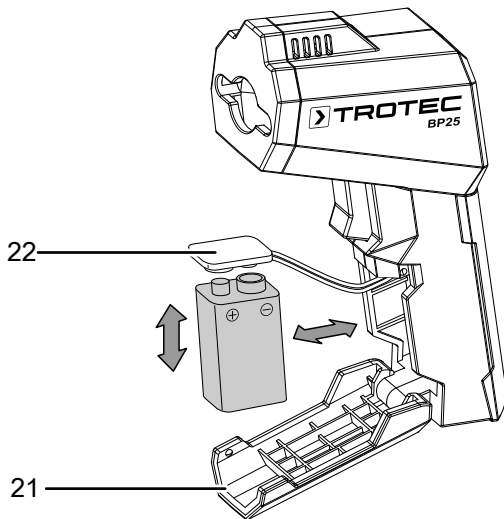

1. Open the battery compartment by folding open the cover (21) with your fingers.
2. Use the battery clip (22) to connect the new battery with correct polarity.
3. Insert the battery in the battery compartment.
4. Close the cover of the battery compartment.

Carrying out a measurement



Info

Please note that moving from a cold area to a warm area can lead to condensation forming on the device's circuit board. This physical and unavoidable effect can falsify the measurement. In this case, the display shows either no measured values or they are incorrect. Wait a few minutes until the device has become adjusted to the changed conditions before carrying out a measurement.

- Ensure that the surface to be measured is free of dust, dirt or similar substances.
 - To be able to gain exact measurement results on surfaces which reflect heavily, stick matt masking tape to the surface or apply matt black paint with a very high and known emissivity.
 - Note the 20:1 ratio of the distance to the measuring spot size. The larger the distance to the object, the larger the measuring spot diameter and hence, the less precise the measured result.
1. Point the device at the object to be measured.
 2. Press the *Measurement* button (3).
 - ⇒ The device switches on.
 - ⇒ The temperature of the measured object is shown on measurement value display 1 (16).
 - ⇒ Depending on the settings, measurement value display 2 (18) shows the dew point temperature, the ambient temperature or the relative humidity (see Changing the measuring mode).
 - ⇒ The scale (15) shows the risk of condensation forming at the measuring spot as a percentage value (0 % = no risk, 100 % = condensation is certain).

You can also recognise the risk of condensation by the colour of the display illumination and the alarm sound (if switched on):

Risk	Display colour	Sounds
Surface temperature in normal range	green	-
Surface temperature near dew point (borderline).	orange	repeated alarm
Temperature of measured surface at or below dew point. ATTENTION: Risk of condensation forming!	red	permanent alarm

Changing the measuring mode

In addition to the temperature at the measuring spot, you can display the current values for dew point temperature, ambient temperature and relative humidity in measurement value display 2 (18). Please proceed as follows to change the measuring mode:

1. Repeatedly press the *MODE* button (6) until the desired indication (10, 12 or 20) appears.
 - ⇒ *DP* indication (20): Measurement value display 2 indicates the current dew point temperature.
 - ⇒ *AT* indication (10): Measurement value display 2 indicates the current ambient temperature.
 - ⇒ *%RH* indication (12): Measurement value display 2 indicates the current relative humidity.

Switching the laser pointer on/off

Ex works the laser pointer is switched off.



Warning of laser radiation

Please note that when the laser is switched on, the laser pointer will light up as soon as you press the *Measurement* button (3) and thus switch on the device.



Warning of laser radiation

Class 2 laser radiation.

Lasers of class 2 only radiate in the visible range and during continuous wave operation (lasting beam) no more than 1 milliwatt (mW) of output will be emitted. Looking directly into the laser beam for a longer period of time (more than 0.25 seconds) can cause damage to the retina.

Avoid looking directly into the laser beam. Never look into the laser beam using optical aides. Do not suppress the winking reflex when looking into the laser beam unintentionally. Never point the laser beam at people or animals.

1. Press the *Laser* button (7).
 - ⇒ The *Laser* indication (11) appears.
 - ⇒ The laser (1) is switched on.
2. Press the *Laser* button again to switch the laser off.
 - ⇒ The laser is switched off.
 - ⇒ The *Laser* indication (11) disappears.



Info

The device memorizes the selected setting when switching off.

Using the HOLD function



You can retain the last measured values on the display.

1. Carry out a measurement.
2. Press the *Measurement* button (3).
 - ⇒ If the laser was previously switched on, it will now be switched off.
 - ⇒ The last measured values are permanently displayed in measurement value displays 1 (16) and 2 (18).
3. Press the *Measurement* button again.
 - ⇒ The device switches back to measuring mode.
 - ⇒ If the laser was switched on before the HOLD function was used, it will now be switched on again.

Changing the temperature unit

1. Press the *Temperature unit* button (5) to change the unit of all measured temperature values.
 - ⇒ The selected unit is shown in the *Temperature unit* indication (14).

Enabling/disabling the alarm

1. Press and hold the *Temperature unit* button (5) for approx. 3 seconds.
 - ⇒ An acoustic signal is emitted.
 - ⇒ The  symbol appears in the *Alarm sound* indication (19).
 - ⇒ The alarm sound is switched on.
2. Press and hold the *Temperature unit* button for approx. 3 seconds.
 - ⇒ The  symbol appears in the *Alarm sound* indication.
 - ⇒ The alarm sound is switched off.

Switching the device off

Notice

In measuring mode, the device switches off automatically after 15 minutes of non-use.

If the HOLD indication (9) is activated, the device switches off automatically after approx. one minute of non-use.

1. Press and hold the *Measurement* button (3) for approx. 3 seconds in any measuring mode.
 - ⇒ The device switches off.

Maintenance and repair

Battery change

The battery is to be changed when the *Battery* indication (13) flashes in the display (8) or the device can no longer be switched on (see section Inserting the battery).

Cleaning

Clean the device with a soft, damp and lint-free cloth. Make sure that no moisture enters the housing. Do not use any sprays, solvents, alcohol-based cleaning agents or abrasive cleaners, but only clean water to moisten the cloth.

Repair

Do not modify the device or install any spare parts. For repairs or device testing, contact the manufacturer.

Errors and faults

The device has been checked for proper functioning several times during production. If malfunctions occur nonetheless, check the device according to the following list.

The device does not switch on:

- Check the charging status of the battery. Change the battery if required, see section Inserting the battery.
- Make sure that the battery is properly positioned. Check the polarity is correct.

Disposal

Always dispose of packing materials in an environmentally friendly manner and in accordance with the applicable local disposal regulations.



The icon with the crossed-out waste bin on waste electrical or electronic equipment is taken from Directive 2012/19/EU. It states that this device must not be disposed of with the household waste at the end of its life. You will find collection points for free return of waste electrical and electronic equipment in your vicinity. The addresses can be obtained from your municipality or local administration. You can also find out about other return options that apply for many EU countries on the website <https://hub.trotec.com/?id=45090>. Otherwise, please contact an official recycling centre for electronic and electrical equipment authorised for your country.

The separate collection of waste electrical and electronic equipment aims to enable the re-use, recycling and other forms of recovery of waste equipment as well as to prevent negative effects for the environment and human health caused by the disposal of hazardous substances potentially contained in the equipment.



In the European Union, batteries and accumulators must not be treated as domestic waste, but must be disposed of professionally in accordance with Directive 2006/66/EC of the European Parliament and of the Council of 6 September 2006 on batteries and accumulators. Please dispose of batteries and accumulators according to the relevant legal requirements.

Only for United Kingdom

According to Waste Electrical and Electronic Equipment Regulations 2013 (SI 2013/3113) (as amended) and the Waste Batteries and Accumulators Regulations 2009 (SI 2009/890) (as amended), devices that are no longer usable must be collected separately and disposed of in an environmentally friendly manner.

Trotec GmbH

Grebener Str. 7
D-52525 Heinsberg

☎ +49 2452 962-400

☎ +49 2452 962-200

✉ info@trotec.com

www.trotec.com