

PHDS 10-230V

EN

ORIGINAL INSTRUCTIONS
IMPACT DRILL



 TROTEC

Table of contents

Notes regarding the instructions 2

Safety 3

Information about the device 7

Transport and storage 8

Start-up 9

Operation 12

Available accessories 16

Errors and faults 16

Maintenance 16

Disposal 17

Declaration of conformity 17

Notes regarding the instructions

Symbols

 **Warning of electrical voltage**
 This symbol indicates dangers to the life and health of persons due to electrical voltage.

 **Warning of hot surface**
 This symbol indicates dangers to the life and health of persons due to hot surface.

 **Warning**
 This signal word indicates a hazard with an average risk level which, if not avoided, can result in serious injury or death.

 **Caution**
 This signal word indicates a hazard with a low risk level which, if not avoided, can result in minor or moderate injury.

Note
 This signal word indicates important information (e.g. material damage), but does not indicate hazards.

 **Info**
 Information marked with this symbol helps you to carry out your tasks quickly and safely.

 **Follow the manual**
 Information marked with this symbol indicates that the instructions must be observed.

 **Wear head protection**
 Information marked with this symbol indicates that you should wear protective headgear.

 **Wear hearing protection**
 Information marked with this symbol indicates that you should wear hearing protection.

 **Wear safety glasses**
 Information marked with this symbol indicates that you should wear eye protection.

 **Wear a protective mask**
 Information marked with this symbol indicates that you should wear a protective mask.

 **Wear protective clothing**
 Information marked with this symbol indicates that you should wear protective clothing.

 **Wear protective gloves**
 Information marked with this symbol indicates that you should wear protective gloves.

 **Wear foot protection**
 Information marked with this symbol indicates that you should wear safety boots.

You can download the current version of the instructions and the EU declaration of conformity via the following link:



PHDS 10-230V



<https://hub.trotec.com/?id=41247>

Safety

General Power Tool Safety Warnings



Warning

Read all safety warnings, instructions, illustrations and specifications provided with this power tool.

Failure to follow all instructions listed below may result in electric shock, fire and/or serious injury.

Save all warnings and instructions for future reference.

The term *power tool* in the warnings refers to your mains-operated (corded) power tool or battery-operated (cordless) power tool.



General Power Tool Safety Warnings – Work area safety

- **Keep work area clean and well lit.** Clutter or dark areas invite accidents.
- **Do not operate power tools in explosive atmosphere, such as in the presence of flammable liquids, gases or dust.** Power tools create sparks which may ignite the dust or fumes.
- **Keep children and bystanders away while operating a power tool.** Distractions can cause you to lose control.



General Power Tool Safety Warnings – Electrical safety

- **Power tool plugs must match the outlet. Never modify the plug in any way. Do not use any adapter plugs with earthed (grounded) power tools.** Unmodified plugs and matching outlets will reduce risk of electric shock.
- **Avoid body contact with earthed or grounded surfaces, such as pipes, radiators, ranges and refrigerators.** There is an increased risk of electric shock if your body is earthed or grounded.
- **Do not expose power tools to rain or wet conditions.** Water entering a power tool will increase the risk of electric shock.
- **Do not abuse the cord. Never use the cord for carrying, pulling or unplugging the power tool. Keep cord away from heat, oil, sharp edges or moving parts.** Damaged or entangled cords increase the risk of electric shock.
- **When operating a power tool outdoors, use an extension cord suitable for outdoor use.** Use of a cord suitable for outdoor use reduces the risk of electric shock.
- **If operating a power tool in a damp location is unavoidable, use a residual current device (RCD) protected supply.** Use of an RCD reduces the risk of electric shock.

- **Hold power tool by insulated gripping surfaces when performing an operation where the cutting accessory may contact hidden wiring or its own cord.** Cutting accessory contacting a "live" wire may make exposed metal parts of the power tool "live" and could give the operator an electric shock.



General Power Tool Safety Warnings – Personal safety

- **Stay alert, watch what you are doing and use common sense when operating a power tool. Do not use a power tool while you are tired or under the influence of drugs, alcohol or medication.** A moment of inattention while operating power tools may result in serious personal injury.



Use personal protective equipment. Always wear eye protection. Protective equipment such as a dust mask, non-skid safety shoes, hard hat or hearing protection used for appropriate conditions will reduce personal injuries.

- **Prevent unintentional starting. Ensure the switch is in the off-position before connecting to power source and/or battery pack, picking up or carrying the tool.** Carrying power tools with your finger on the switch or energising power tools that have the switch on invites accidents.
- **Remove any adjusting key or wrench before turning the power tool on.** A wrench or a key left attached to a rotating part of the power tool may result in personal injury.
- **Do not overreach. Keep proper footing and balance at all times.** This enables better control of the power tool in unexpected situation.
- **Dress properly. Do not wear loose clothing or jewellery. Keep your hair and clothing away from moving parts.** Loose clothes, jewellery or long hair can be caught in moving parts.
- **If devices are provided for the connection of dust extraction and collection facilities, ensure these are connected and properly used.** Use of dust collection can reduce dust-related hazards.
- **Do not let familiarity gained from frequent use of tools allow you to become complacent and ignore tool safety principles.** A careless action can cause severe injury within a fraction of a second.



General Power Tool Safety Warnings – Power tool use and care

- **Do not force the power tool. Use the correct power tool for your application.** The correct power tool will do the job better and safer at the rate for which it was designed.
- **Do not use the power tool if the switch does not turn it on and off.** Any power tool that cannot be controlled with the switch is dangerous and must be repaired.
- **Disconnect the plug from the power source and/or remove the battery pack, if detachable, from the power tool before making any adjustments, changing accessories, or storing power tools.** Such preventive safety measures reduce the risk of starting the power tool accidentally.
- **Store idle power tools out of the reach of children and do not allow persons unfamiliar with the power tool or these instructions to operate the power tool.** Power tools are dangerous in the hands of untrained users.
- **Maintain power tools and accessories. Check for misalignment or binding of moving parts, breakage of parts and any other condition that may affect the power tool's operation. If damaged, have the power tool repaired before use.** Many accidents are caused by poorly maintained power tools.
- **Keep cutting tools sharp and clean.** Properly maintained cutting tools with sharp cutting edges are less likely to bind and are easier to control.
- **Use the power tool, accessories and tool bits etc. in accordance with these instructions, taking into account the working conditions and the work to be performed.** Use of the power tool for operations different from those intended could result in a hazardous situation.
- **Keep handles and grasping surfaces dry, clean and free from oil and grease.** Slippery handles and grasping surfaces do not allow for safe handling and control of the tool in unexpected situations.



General Power Tool Safety Warnings – Service

- **Have your power tool serviced by a qualified repair person using only identical replacement parts.** This will ensure that the safety of the power tool is maintained.



Device-specific safety warnings for impact drills



Wear eye and mouth protection when processing materials that may contain harmful substances (e.g. asbestos).



Wear ear protectors when impact drilling. Exposure to noise can cause hearing loss.

- **Use the auxiliary handle(s).** Loss of control can cause personal injury.
- **Hold the power tool by insulated gripping surfaces, when performing an operation where the cutting accessory or fasteners may contact hidden wiring or its own cord.** Cutting accessory contacting a "live" wire may make exposed metal parts of the power tool "live" and could give the operator an electric shock.
- **Use appropriate detection equipment to track down concealed supply lines or consult the local utility companies.** Contact with electrical lines may result in fire and electric shock. Damaging a gas line may lead to an explosion. Penetrating a water line causes property damage and may cause an electric shock.
- **Vibrations can be harmful to the human hand-arm system.** Keep the vibration exposure time to a minimum.
- **During operation hold onto the power tool with both hands.** Make sure that you stand firmly on the ground. It is safer to handle the power tool with two hands.
- **Secure the workpiece.** The grip of tensioning devices or a vice is more secure than holding the workpiece only by hand.



Protect yourself and others present from injuries caused by splintering and flying bits and pieces.



Wear a hard hat, eye protection, a dust mask and safety boots. If necessary, put up partition panels as shield against breaking off debris.



- **Before starting to work, always make sure that the insertion tool is firmly clamped inside the drill chuck.** Insertion tools that are not locked in place could be catapulted out of the power tool upon switch-on and lead to injuries.

- **Before switching on the power tool, ensure that the insertion tool can move freely.** If the device is switched on with a jammed insertion tool, the resulting forces can be extreme causing the device to kick out sideways.
- **Immediately switch off the power tool if the insertion tool blocks.** The power tool can lash out to the side owing to the forces that build up consequently.
- **Regularly check the drill chuck for wear or damage.**
- **Only start a percussive power tool while holding it against a workpiece (wall, ceiling, etc.).**
- **Wait until the power tool has come to a standstill, before putting it down.**
- **Processing metal creates flying sparks.** Make sure that nobody's safety is jeopardized and that there are no combustible materials near the working area. Fire hazard!
- **Avoid drilling in lead paint or other harmful materials.**
- **Always keep the power cable behind the device.**
- **Make sure that the venting slots are not covered during operation.** Do not insert any objects into the venting slots.
- **The device must always be clean, dry and free from oil or greases.**



Safety instructions when using long drill bits

- **Never operate at higher speed than the maximum speed rating of the drill bit.** At higher speeds, the bit is likely to bend if allowed to rotate freely without contacting the workpiece, resulting in personal injury.
- **Always start drilling at low speed and with the bit tip in contact with the workpiece.** At higher speeds, the bit is likely to bend if allowed to rotate freely without contacting the workpiece, resulting in personal injury.
- **Apply pressure only in direct line with the bit and do not apply excessive pressure.** Bits can bend causing breakage or loss of control, resulting in personal injury.

Intended use

Only use the device PHDS 10-230V:

- for screwing in and loosening screws,
- for drilling in wood, plastic, ceramic and metal,
- for impact drilling in masonry, bricks and stone,

whilst adhering to the technical data (see operating manual).

We recommend using the power tool with original Trotec accessories.

Foreseeable misuse

The device is not intended for drilling in natural stone.

Any other use than the one described in chapter "Intended use" is regarded as reasonably foreseeable misuse.

Personnel qualifications

People who use this device must:

- have read and understood the instructions, especially the Safety chapter.

Symbols on the device

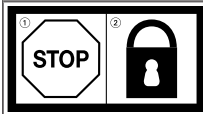
Symbols	Meaning
	<p>This symbol located on the device indicates that it is prohibited to press the spindle lock during operation. Pressing the spindle lock during operation can damage the motor and / or gear.</p>

Personal protective equipment



Wear protective headgear.

With it you protect your head from splintering, falling and flying pieces which could cause injuries.



Wear hearing protection.

Excessive noise can lead to hearing loss.



Wear eye protection.

With it you protect your eyes from splintering, falling and flying pieces which could cause injuries.



Wear a protective mask.

It saves you from inhaling harmful dusts generated when processing workpieces.



Wear protective gloves.

They protect your hands from burns, crushing injuries and skin abrasions.



Wear tight-fitting protective clothing.

This protects you from the draw-in and entanglement hazard posed by rotating parts.



Wear safety boots.

They protect your feet from splintering, falling and flying pieces which could cause injuries.

Residual risks



Warning of electrical voltage

Electric shock from insufficient insulation.
Check the device for damages and proper functioning before each use.
If you notice damages, no longer use the device.
Do not use the device when the device or your hands are damp or wet!



Warning of electrical voltage

Work on the electrical components must only be carried out by an authorised specialist company!



Warning of electrical voltage

Before any work on the device, remove the mains plug from the mains socket!
Hold onto the mains plug while pulling the power cable out of the mains socket.



Warning of electrical voltage

There is a risk of a short-circuit due to liquids penetrating the housing!
Do not immerse the device and the accessories in water. Make sure that no water or other liquids can enter the housing.



Warning of hot surface



The insertion tool might still be hot after the application. Burn hazard when touching the insertion tool.

Do not touch the insertion tool bare-handed!
Wear protective gloves!



Warning



Toxic dusts!



The harmful / toxic dusts produced during operation pose of risk to the health of the operator and persons in the vicinity.

Wear eye protection and a dust mask!



Warning

Do not process materials containing asbestos.
Asbestos is considered carcinogenic.



Warning

Make sure not to hit power, gas or water lines when working with a power tool.
If necessary, use a pipe detector to check the wall you want to drill in or slit open.



Warning

Risk of injuries caused by flying parts or bursting tool heads.



Warning

Dangers can occur at the device when it is used by untrained people in an unprofessional or improper way!
Observe the personnel qualifications!



Warning

The device is not a toy and does not belong in the hands of children.



Warning

Risk of suffocation!
Do not leave the packaging lying around. Children may use it as a dangerous toy.



Warning

The tool holder must be firmly locked in place before switching the device on, for an insufficiently or incorrectly clamped accessory could be catapulted out of the tool holder uncontrollably upon switch-on.



Caution

Vibration emissions can cause a health hazard if the device is used for an extended period of time or if it is not properly handled and maintained.



Caution

Keep a sufficient distance from heat sources.

Note

If you store or transport the device improperly, the device may be damaged.
Note the information regarding transport and storage of the device.

Note

Only change the rotational direction when the device is at a standstill! Otherwise the device might be damaged.

Note

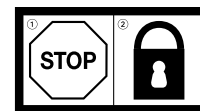

Only press the lock button when the device is at a standstill! Otherwise the device might be damaged.

Note

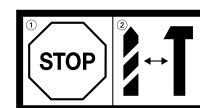

Only actuate the function selector switch when the device is at a standstill! Otherwise the device might be damaged.

Behaviour in the event of an emergency

1. Switch off the device.
2. In an emergency, disconnect the device from the mains feed-in: Hold onto the mains plug while pulling the power cable out of the mains socket.
3. Do not reconnect a defective device to the mains.

Information about the device

Device description

The impact drill PHDS 10-230V comes with a drilling setting and an impact drilling setting.

A function selector switch permits the simple switch-over between functions.

The infinitely variable impact rate and speed control allows you to optimally adjust the exertion of force to every application and material.

The keyless drill chuck with lock function further enables an easy and tool-free exchange of the insertion tools.

The additional handle, which is rotatable by 360° and lockable, ensures more stability and safety during the drilling / impact drilling operation.

The device can be used in continuous operation. Moreover, it can be used to tighten or loosen screws when using the suitable tool bits.

Device depiction

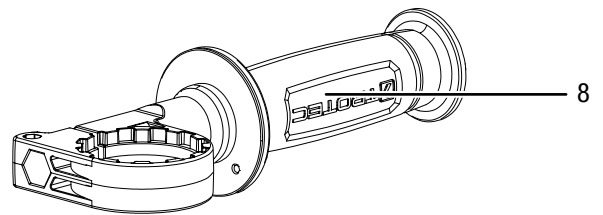
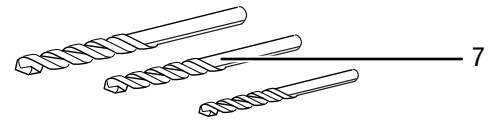
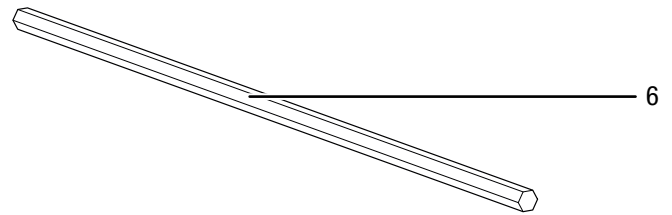
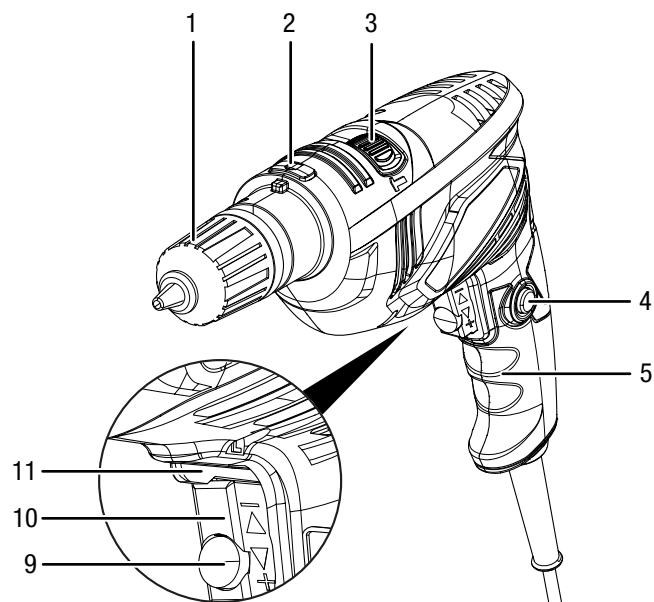

No.	Designation
1	Keyless drill chuck with lock function
2	Spindle lock button
3	Function selector switch
4	Locking switch for continuous operation
5	Handle
6	Depth stop
7	Drill bits
8	Additional handle
9	Speed selection setting wheel for continuous operation
10	On/off switch / speed selection
11	Clockwise/counter-clockwise rotation switch

Scope of delivery

- 1 x Impact drill PHDS 10-230V
- 1 x Depth stop
- 3 x Drill bit (5x85 mm, 6x100 mm, 8x120 mm)
- 1 x Additional handle
- 1 x Transport case
- 1 x Manual

Technical data

Parameter	Value
Model	PHDS 10-230V
Power supply	230 V / 50 Hz
Power consumption	650 W
Idle speed	50 to 3000 rpm
Impact frequency	800 to 48000 spm
Max. torque	7.5 Nm
Chucking range	max. 13 mm
Max. drilling diameter	
Wood	30 mm
Metal	10 mm
masonry / bricks	13 mm
Weight	2 kg
Protection class	II / 
Sound values according to EN 62841-2-1	
Sound pressure level	95 dB(A)
Sound power level	106 dB(A)
Uncertainty K	5 dB(A)
Vibration information according to EN 62841-2-1	
Total vibration emission value:	
Impact drilling in brickwork with main handle $a_{h,D}$	21.795 m/s ²
Uncertainty K	1.5 m/s ²
Impact drilling in brickwork with additional handle $a_{h,D}$	12.605 m/s ²
Uncertainty K	1.5 m/s ²
Drilling in metal with main handle $a_{h,D}$	4.041 m/s ²
Uncertainty K	1.5 m/s ²
Drilling in metal with additional handle $a_{h,D}$	2.713 m/s ²
Uncertainty K	1.5 m/s ²



Wear hearing protection.

Excessive noise can lead to hearing loss.

Information on noise and vibration:

- The specified total vibration **and noise emission values** were measured by means of a test procedure standardized in EN 62841 and can be consulted for the comparison of one power tool with another.
- The specified total vibration **and noise emission values** can also be used for preliminary load assessment.



Caution

Vibration emissions can cause a health hazard if the device is used for an extended period of time or if it is not properly handled and maintained.

- The actual vibration **and noise emission** may differ from the stated values during operation of the power tool. This depends on how the power tool is used and especially on the type of workpiece being processed. Try to keep the vibration load to a minimum. Exemplary measures for reducing the vibration load include wearing gloves during operation of the tool and the limitation of working hours. All parts of an operating cycle must be considered for this (e.g. times at which the power tool is switched off and times when it is switched on but runs without load).

Transport and storage

Note

If you store or transport the device improperly, the device may be damaged.

Note the information regarding transport and storage of the device.

Transport

For transporting the device, use the transport case included in the scope of delivery in order to protect the device from external influences.

Before transporting the device, observe the following:

- Switch off the device.
- Hold onto the mains plug while pulling the power cable out of the mains socket.
- Allow the device to cool down.
- Remove the tool from the tool holder.

Storage

Before storing the device, observe the following:

- Switch off the device.
- Hold onto the mains plug while pulling the power cable out of the mains socket.
- Allow the device to cool down.
- Remove the tool from the tool holder.
- Clean the device as described in the Maintenance chapter.
- For storing the device, use the transport case included in the scope of delivery in order to protect the device from external influences.

When the device is not being used, observe the following storage conditions:

- dry and protected from frost and heat
- ambient temperature below 45 °C
- protected from dust and direct sunlight inside the transport case

Start-up

Unpacking the device

- Take the transport case out of the packaging.



Warning of electrical voltage

Electric shock from insufficient insulation.
Check the device for damages and proper functioning before each use.

If you notice damages, no longer use the device.

Do not use the device when the device or your hands are damp or wet!

- Check the contents of the transport case for completeness and look for damages.



Warning

Risk of suffocation!

Do not leave the packaging lying around. Children may use it as a dangerous toy.

- Dispose of the packaging material according to the national regulations.

Mounting the additional handle

The additional handle (8) should be mounted before start-up. Do not use the device without the additional handle.

The position of the additional handle may be adjusted by 360° as required.

To do so, please proceed as follows:

1. Loosen the screw connection of the additional handle (8) by holding onto the top of the additional handle and rotating the gripping surface to the left.
2. Fit the additional handle (8) on the device by pushing it over the keyless drill chuck.

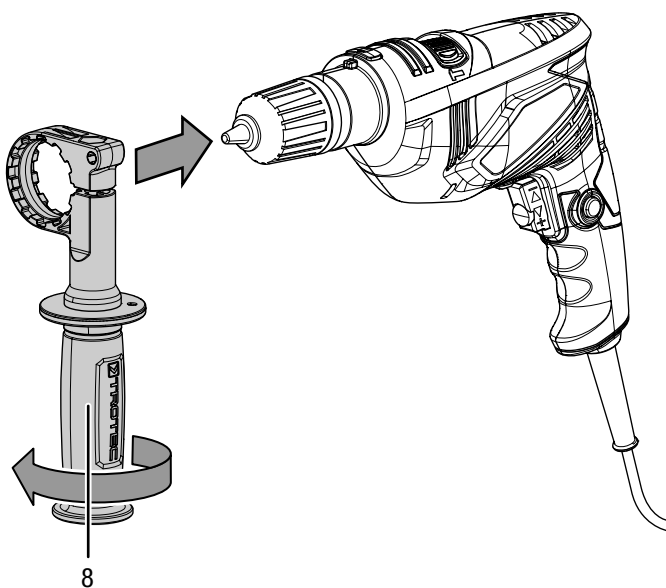

3. Turn the additional handle (8) into the desired position.

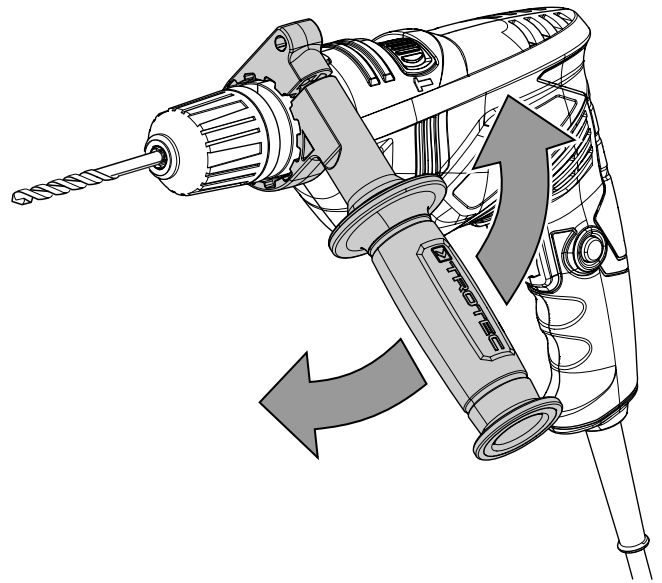

4. To fix the additional handle (8) in the desired position, slide the additional handle back (8). Note that one of the openings at the additional handle (8) must fit on the protrusion at the device as shown below:

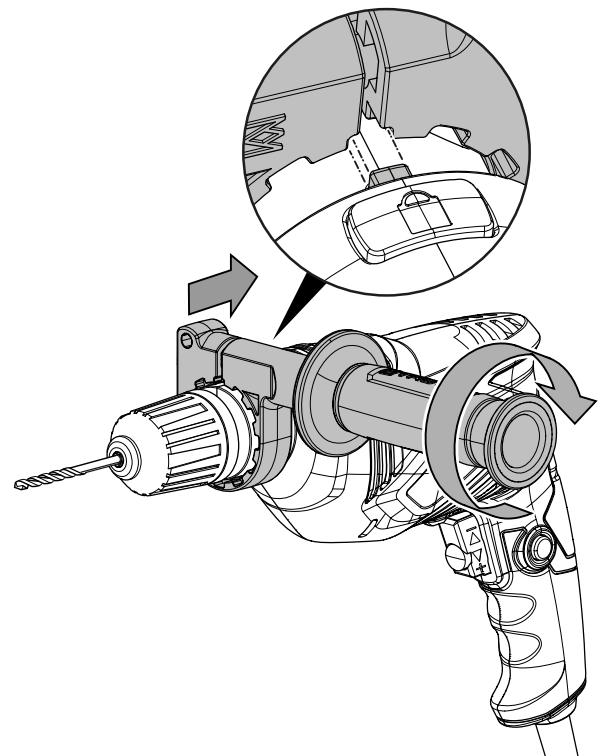

5. Tighten the screw connection of the additional handle (8) by rotating the gripping surface to the right.
6. Check the additional handle (8) for tight fit. If necessary, tighten the additional handle further.

Adjusting the position of the additional handle

The position of the additional handle may be adjusted by 360° as required.

To do so, please proceed as follows:

1. Loosen the screw connection of the additional handle (8) by rotating the gripping surface to the left.
2. Push the additional handle (8) to the front until it can be freely rotated to the left and right.

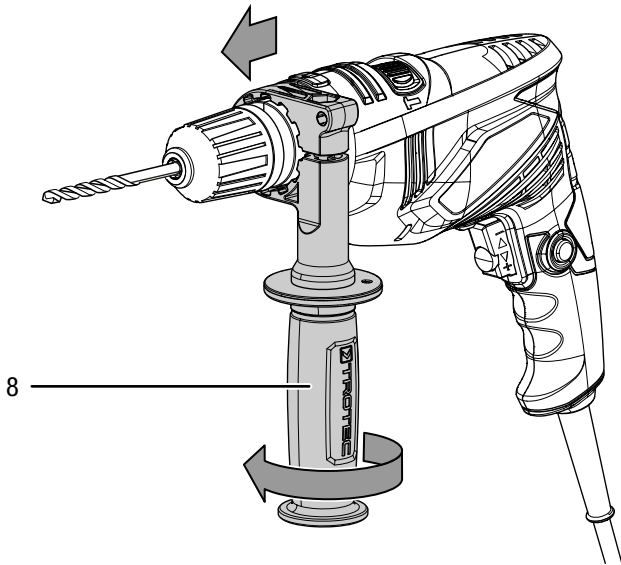

3. Proceed as described in steps 3 to 6 in the chapter Mounting the additional handle.

Tool change

The device is equipped with a keyless drill chuck with lock function.



Warning of electrical voltage

Before any work on the device, remove the mains plug from the mains socket!

Hold onto the mains plug while pulling the power cable out of the mains socket.

Note

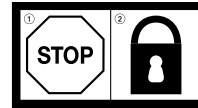

Only press the lock button when the device is at a standstill! Otherwise the device might be damaged.

Please proceed as follows to remove or insert tools:

1. Press and hold the spindle lock button (2).
2. Open the keyless drill chuck (1).

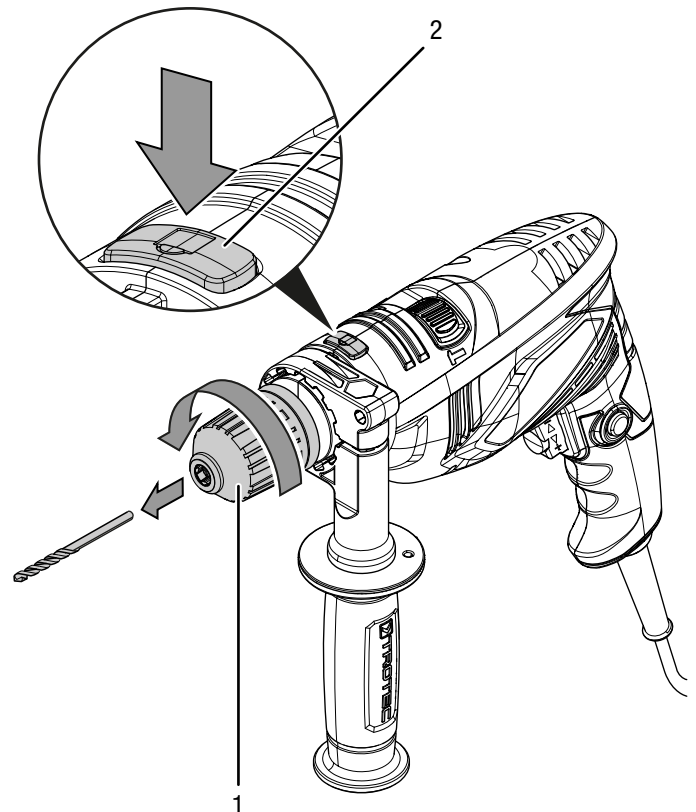

3. Let go of the spindle lock button (2).
4. Take the drill bit (if any) out of the keyless drill chuck (1).
5. Insert the suitable drill bit into the keyless drill chuck (1).
6. Press and hold the spindle lock button (2) once again.

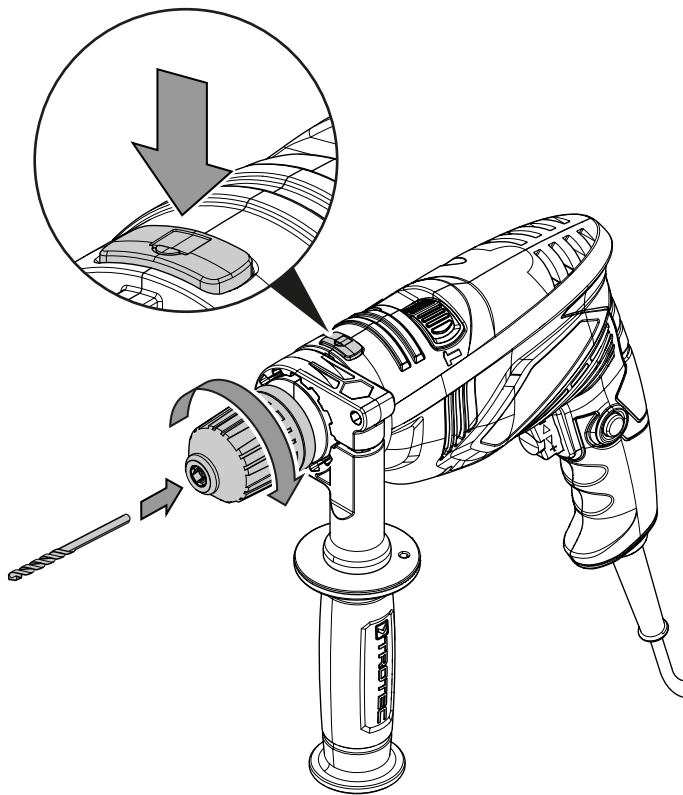

7. Tighten the keyless drill chuck (1).
8. Let go of the spindle lock button (2).
9. Make sure that the drill bit is attached securely.

Inserting and using the depth stop (optional)

With the depth stop you can determine the penetration depth of the drill bits.



Info

When using wall plugs, pay attention to the precise drilling depth. If the drilled hole is too deep, the wall plug will slide too far into the wall or workpiece. If the hole is too small, the wall plug will protrude.

1. Loosen the screw connection of the additional handle (8) by rotating the gripping surface to the left.
2. Insert the depth stop (6). When doing so, make sure that the notches of the depth stop point to the device.

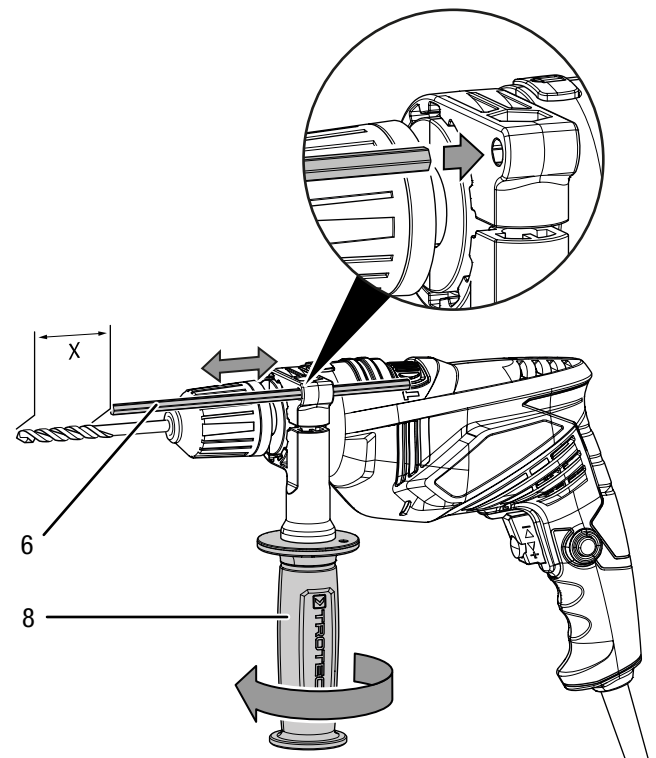

3. Adjust the depth stop to the desired length.
4. Tighten the screw connection of the additional handle (8) by rotating the gripping surface to the right.

5. Check the additional handle (8) for tight fit. If necessary, tighten the additional handle further.

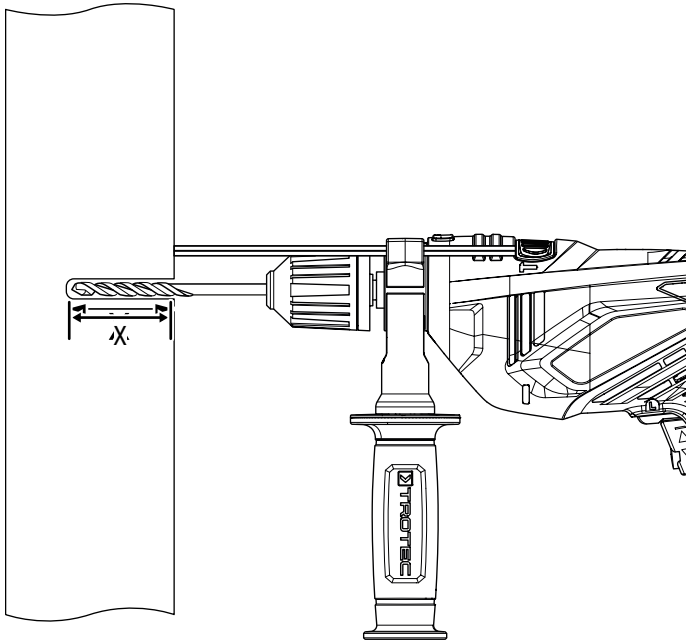

Connecting the power cable

1. Insert the mains plug into a properly secured mains socket.

Operation

Tips and notes on handling the impact drill

Drilling in general:

- Take short breaks regularly during drilling. When doing so, take the drill bit out of the drill hole so that the drill bit can cool down.
- Secure the workpiece in a tensioning device or vice.
- Select the speed depending on the material characteristics and the size of the drill bit:
 - High speed for small drilling diameter or soft material
 - Low speed for large drilling diameter or hard material
- Use a suitable aid to mark the intended location of the drill hole.
- Select a low speed for spudding.

Drilling in metal:

- Use suitable metal drill bits (e.g. drill bits made of *high-speed steel* (HSS)).
- For larger drilling diameters, use a smaller drill bit for pre-drilling.
- To achieve ideal results, the drill bit should be cooled with a suitable lubricant.
- Metal drill bits may also be used for drilling in plastic.

Drilling in wood:

- Use drill bits suitable for wood.
- Place a block of wood under the workpiece or drill in from both sides so that the wood cannot break off when it is being drilled through.
- Use a wood drill bit with centring tip. For deep drill holes, use an auger bit; for large drilling diameters, use a Forstner bit.

Impact drilling in masonry / bricks:

- Use a drill bit suitable for masonry / bricks.

Screwing:

- When using screwdriver bits, always use a universal bit holder. Only use screwdriver bits that are suitable for the screw head.

Switching the device on and off

Wear your personal protective equipment when working with the device.

1. Check whether the tool clamped in and the selected speed level are suitable for the intended application.
2. Check whether the workpiece is secured and the worktop prepared correspondingly.
3. Check whether the correct rotational direction is selected.
4. If you work with activated impact mechanism, press the tool against the workpiece.
5. Hold onto the device with both hands.
6. Press the on/off switch (10) and hold it during operation. You can control the speed by pressing the on/off switch (10): press lightly for a low speed; press firmly for a high speed. The previously selected speed applies.
 - ⇒ The device operates with the previously selected settings.

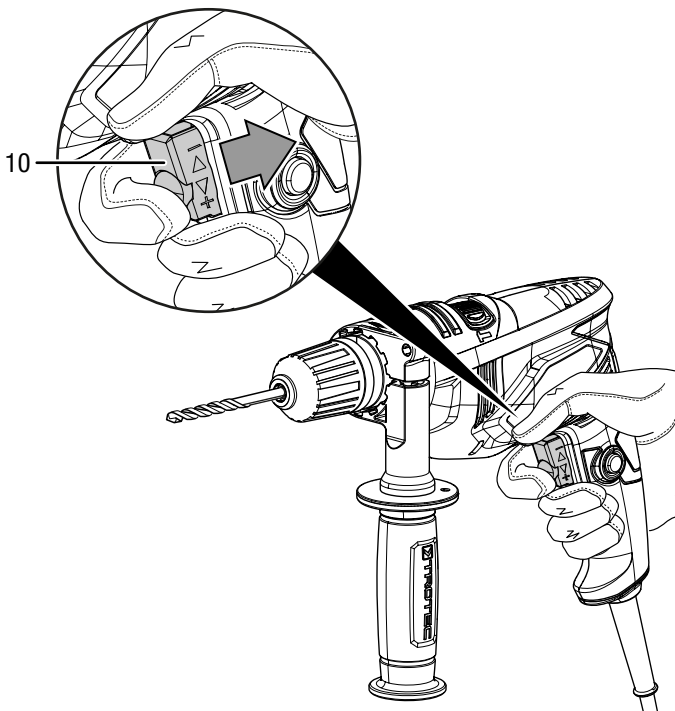

Switching continuous operation on and off

When continuous operation is activated, the on/off switch does not have to be held permanently, which makes working more comfortable.

1. Proceed as described in the chapter Switching the device on and off, steps 1 to 5.
2. Press the button for continuous operation (4) with your thumb until it locks in place completely.

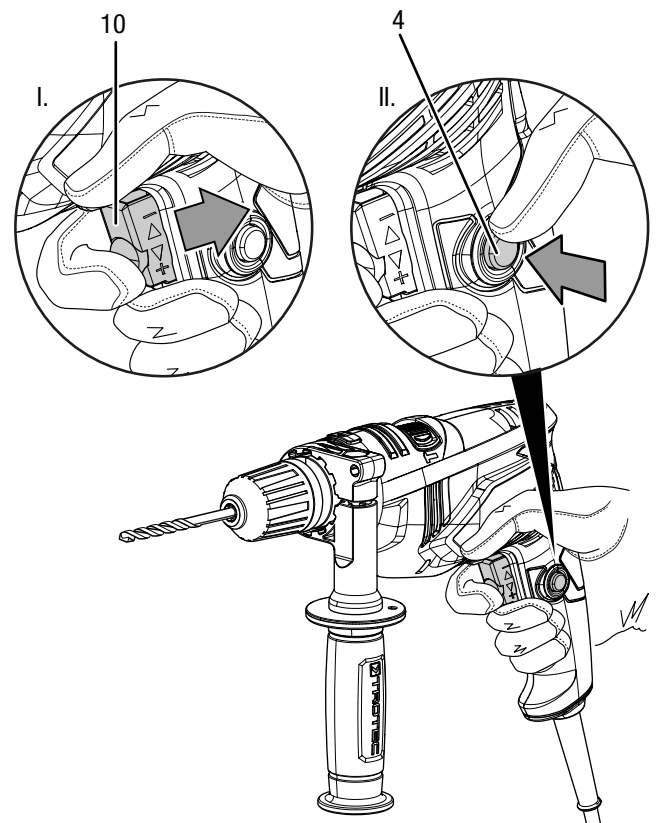

3. Let go of the on/off switch (10) and continue holding the device.
 - ⇒ The on/off switch is locked in place.
 - ⇒ The device keeps running and continuous operation is activated.

7. Let go of the on/off switch (10) to stop the device.

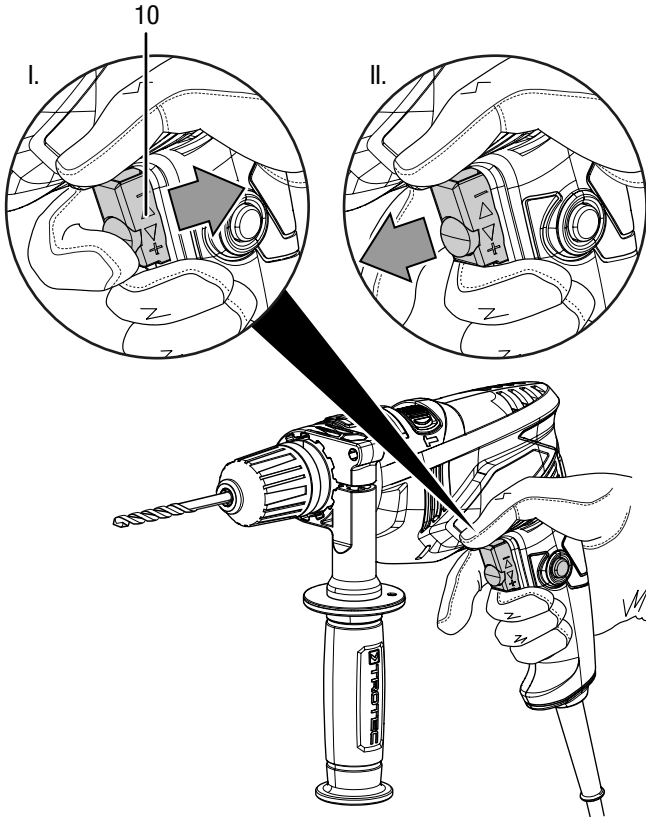

4. Press the on/off switch (10) again to deactivate continuous operation.
- ⇒ The speed increases briefly.
 - ⇒ The button for continuous operation (4) automatically returns to its initial position.



5. Let go of the on/off switch (10) to stop the device.

Speed selection

The required speed depends on the material and the operating conditions and can be determined by way of field-testing.

- Select a low level for soft materials or screws that are easy to move.
- Select a high level for hard materials or screws that are difficult to move.
- For drilling and screwing, select the drilling setting indicated by the symbol .
- For impact drilling, select the impact drilling setting indicated by the symbol .



Info

When unscrewing, note the setting of the rotational direction! The clockwise/counter-clockwise rotation direction indicator (11) indicates in which direction the screws will be rotated.

Do not use the impact drilling setting  for screwing!

1. Turn the setting wheel (9) towards + or - to increase or reduce the speed.

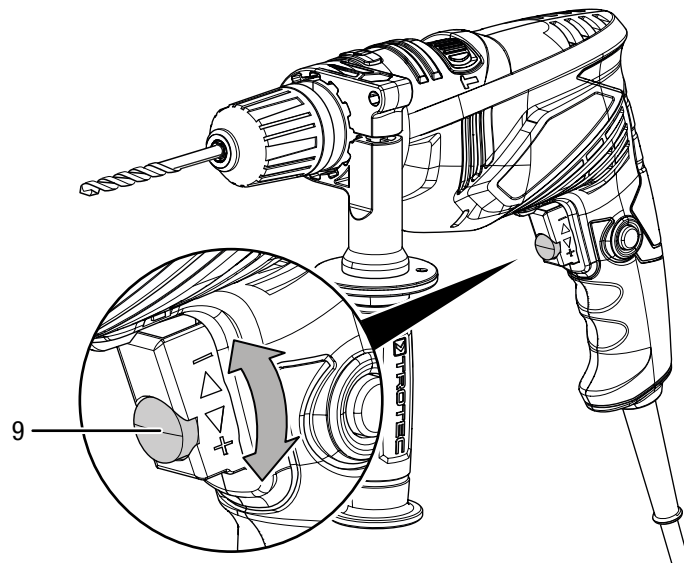

Info

Note that the speed is limited by the on/off switch, which can only be pressed down to the set speed.

Selecting the operating mode

The function selector switch (3) is used to select drilling or impact drilling operating mode.

Note

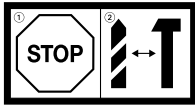

Only actuate the function selector switch when the device is at a standstill! Otherwise the device might be damaged.

1. Set the function selector switch (3) to the desired position.

⇒ **Operating mode: Drilling**

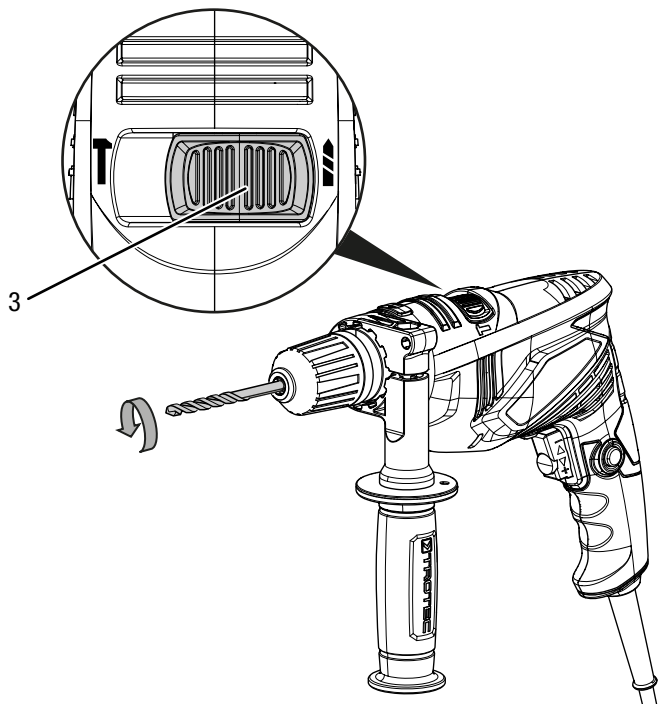

⇒ **Operating mode: Impact drilling**

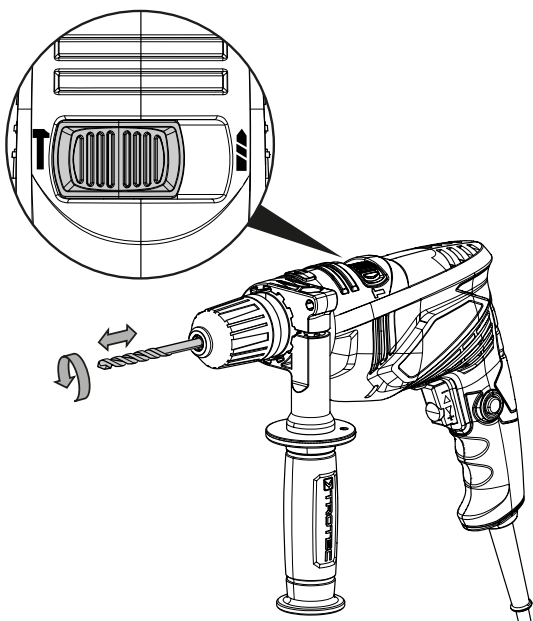

Selecting the rotational direction

Note

Only change the rotational direction when the device is at a standstill! Otherwise the device might be damaged.

The motor's rotational direction can be changed by means of the switch for clockwise/counter-clockwise rotation (11).

1. Set the switch to **R** for rotation to the right.

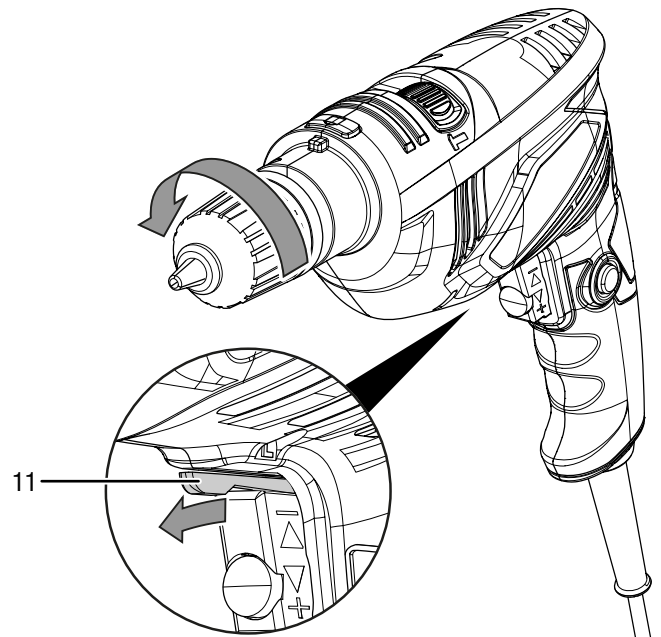

2. Set the switch to **L** for rotation to the left.

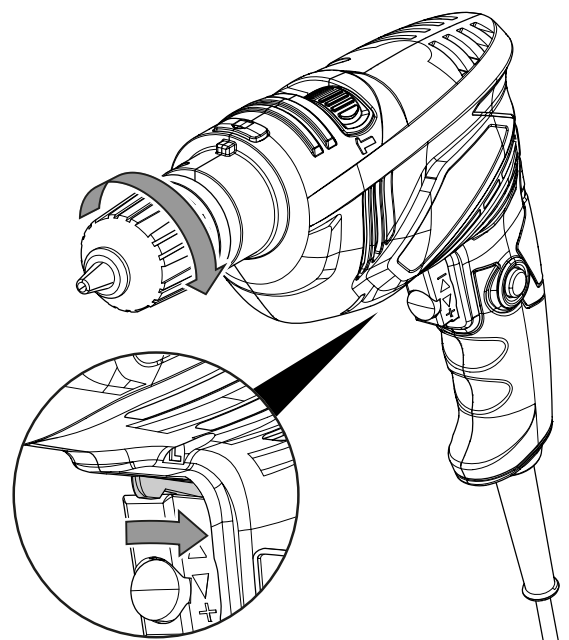

Shutdown



Warning of electrical voltage

Do not touch the mains plug with wet or damp hands.

- Switch off the device.
- Hold onto the mains plug while pulling the power cable out of the mains socket.
- If required, allow the device to cool down.
- Remove the tool from the device (see Start-up chapter).
- Clean the device according to the Maintenance chapter.
- Store the device according to the Storage chapter.

Available accessories



Warning

Only use accessories and additional equipment specified in the instructions. Using insertion tools or accessories other than those specified in the instructions may cause a risk of injury.

Accessories	Article number
Rock drill bit set, 15-piece	6.000.001.151
Wood drill bit set, 15-piece	6.200.001.101
Metal drill bit set HSS, 15-piece	6.200.001.131
Screw bit set, 32-piece	6.200.001.001

Errors and faults

The device has been checked for proper functioning several times during production. If malfunctions occur nonetheless, check the device according to the following list.

Troubleshooting tasks which require the housing to be opened must only be carried out by an authorized specialist electrical company or by Trotec.

Slight smoke or odour are emitted during first use:

- This is not a fault. These phenomena disappear after a brief runtime.

The device does not start:

- Check the power connection.
- Check the power cable and mains plug for damages. If you notice damages, do not try to take the device back into operation. To avoid safety hazards, do not perform any repairs. Send the device to a specialist electrical company or to Trotec to have the power cable and mains plug replaced.
- Check the on-site fusing.



Info

Wait for at least 10 minutes before switching the device back on.

The drill bit does not penetrate / hardly penetrates the material:

- Check whether the correct speed level is selected. A higher speed level may be required in harder material. If required, turn the setting wheel towards +.
- Check whether the correct drill bit is selected.
- Check whether the device is set to counter-clockwise rotation. For drilling, it is necessary to switch over to clockwise rotation.
- Check whether the characteristics of the material require the use of a rotary hammer.

The device becomes hot:

- Check whether the tool is suitable for the tasks to be carried out.
- Keep the venting slots clear to prevent the motor from overheating.
- Select a lower speed.



Info

Wait for at least 10 minutes before switching the device back on.

Note

Wait for at least 3 minutes after maintenance and repair work. Only then switch the device back on.

Your device still does not operate correctly after these checks?

Please contact the customer service. If necessary, bring the device to an authorized specialist electrical company or to Trotec for repair.

Maintenance

Activities required before starting maintenance



Warning of electrical voltage

Do not touch the mains plug with wet or damp hands.

- Switch off the device.
- Hold onto the mains plug while pulling the power cable out of the mains socket.
- Allow the device to cool down completely.



Warning of electrical voltage

Maintenance tasks which require the housing to be opened must only be carried out by authorised specialist companies or by Trotec.

Notes on maintenance

Inside the device, there are no parts that need to be maintained or lubricated by the user.

Cleaning

The device should be cleaned before and after each use.

Note

The device does not have to be lubricated after cleaning.



Warning of electrical voltage

There is a risk of a short-circuit due to liquids penetrating the housing!

Do not immerse the device and the accessories in water. Make sure that no water or other liquids can enter the housing.

- Clean the device with a soft, damp and lint-free cloth. Make sure that no moisture enters the housing. Protect electrical components from moisture. Do not use any aggressive cleaning agents such as cleaning sprays, solvents, alcohol-based or abrasive cleaners to dampen the cloth.
- Dry the device with a soft, lint-free cloth.
- Dry the bits with a soft, lint-free cloth.
- Remove any drilling dust and, if applicable, wood chips from the keyless drill chuck.
- Keep the ventilation openings free from dust deposits to prevent overheating of the motor.

Disposal



The icon with the crossed-out waste bin on waste electrical or electronic equipment stipulates that this equipment must not be disposed of with the household waste at the end of its life. You will find collection points for free return of waste electrical and electronic equipment in your vicinity. The addresses can be obtained from your municipality or local administration. For further return options provided by us please refer to our website www.trotec24.com.

The separate collection of waste electrical and electronic equipment aims to enable the re-use, recycling and other forms of recovery of waste equipment as well as to prevent negative effects for the environment and human health caused by the disposal of hazardous substances potentially contained in the equipment.

Declaration of conformity

The text below sets out the contents of the declaration of conformity. The signed declaration of conformity can be found at <https://hub.trotec.com/?id=41247>.

Declaration of conformity

in accordance with the EC Machinery Directive 2006/42/EC, Annex II, Part 1, Section A

Herewith, we – Trotec GmbH – declare that the machinery designated below was developed, constructed and produced in compliance with the requirements of the EC Machinery Directive in the version 2006/42/EC.

Product model / Product: PHDS 10-230V

Product type: Impact drill

Year of manufacture as of: 2019

Relevant EU directives:

- 2014/30/EU: 29 March 2014

Applied harmonised standards:

- EN ISO 12100:2010
- EN 61000-3-2:2014
- EN 61000-3-3:2013
- EN 62841-1:2015
- EN 62841-2-1:2018

Applied national standards and technical specifications:

- EN 55014-1:2017
- EN 55014-2:2015
- IEC 62841-1:2014
- IEC 62841-2-1:2017

Manufacturer and name of the authorised representative of the technical documentation:

Trotec GmbH

Grebener Straße 7, D-52525 Heinsberg

Phone: +49 2452 962-400

E-mail: info@trotec.de

Place and date of issue:

Heinsberg, 04.07.2017

Detlef von der Lieck, Managing Director

Trotec GmbH

Grebener Str. 7
D-52525 Heinsberg

☎ +49 2452 962-400

☎ +49 2452 962-200

✉ info@trotec.com

www.trotec.com